

Nonlinear Stochastic Homogenization (*).

GIANNI DAL MASO - LUCIANO MODICA

Sunto. – *In questo lavoro viene studiata l'omogeneizzazione stocastica per funzionali integrali del Calcolo delle Variazioni con integrando dipendente dalla variabile spaziale e convesso nel gradiente, soddisfacente alle usuali ipotesi di uniforme coercitività e limitatezza. Il risultato generale ottenuto copre un largo spettro di fenomeni riguardanti materiali con disposizione casuale di più componenti il cui comportamento fisico è retto da equazioni variazionali non lineari.*

0. – Introduction.

The mathematical theory of homogenization for periodic structures has been greatly developed in the 1970's by E. DE GIORGI, S. SPAGNOLO, L. TARTAR, N. S. BAHVALOV, I. BABUSKA, E. SANCHEZ-PALENCIA, A. BENSOUSSAN, J. L. LIONS, G. C. PAPANICOLAOU, C. SBORDONE, P. MARCELLINI, V. V. ZHIKOV, S. M. KOZLOV, O. A. OLEINIK, KHA T'EN NGOAN, F. MURAT and many other authors (see [1] and the bibliography of [6]).

More recently, some attention has been devoted to the stochastic homogenization, in particular in boundary value problems for the linear second-order uniformly elliptic equations in variational form

$$(1) \quad \sum_{i,j=1}^n D_i \left(a_{ij} \left(\omega, \frac{x}{\varepsilon} \right) D_j u \right) = \varphi \quad (\varepsilon \rightarrow 0 +)$$

where ω is a random parameter and the matrix field (a_{ij}) is mainly supposed to be bounded, positive definite, homogeneous and ergodic: see S. M. KOZLOV [13], V. V. YURINSKIY [24], G. C. PAPANICOLAOU and S. R. S. VARADHAN [19] and the volume [3]. The physical meaning is obvious: the structures to be homogenized are not periodic but, in a sense, only stochastically periodic and this corresponds naturally to a large number of real phenomena in physics, chemistry and engineering.

In this paper we propose a new scheme to study stochastic homogenization, which covers the Euler equations of a broad class of convex integral functionals, hence in particular the linear equations (1) (arising from integral quadratic forms)

(*) Entrata in Redazione il 29 settembre 1985.

Indirizzo degli AA.: G. DAL MASO: Istituto di Matematica, Università di Udine, Italia;
L. MODICA, Dipartimento di Matematica, Università di Pisa, Italia.

but also much more general nonlinear variational equations. In the case (1) we obtain independently the results already known, except for a slight difference about which we shall return afterwards in the remark (a) of this introduction.

The main feature of our scheme is to pass from the point of view of the stochastic differential equations to be solved to that one of the random integral functionals to be minimized. In the classical, let us say «deterministic», homogenization, this passage is the convergence in energy of E. DE GIORGI and S. SPAGNOLO [8] and was performed for the convex integral functionals by P. MARCELLINI [16]. The present paper may be considered a stochastic version of the Marcellini's one and also a generalization of it.

Let us describe more closely the content of this work. First, we introduce the class \mathcal{F} of all the integral functionals of the form

$$F(u, A) = \int_A f(x, Du(x)) \, dx$$

(u real function in a suitable function space U , A open bounded subset of \mathbf{R}^n) with $f(x, p)$ measurable in x , convex in p and such that

$$c_1|p|^\alpha \leq f(x, p) \leq c_2(|p|^\alpha + 1)$$

where $0 < c_1 \leq c_2$ and $\alpha > 1$ are fixed real constants.

As we want to study the random integral functionals, that is the «measurable» maps $\omega \rightarrow F(\omega)$ of a probabilistic space Ω into \mathcal{F} , and their convergence, we need some structure on \mathcal{F} . Then we construct on \mathcal{F} a distance d so that the following two main conditions are fulfilled:

(i) (\mathcal{F}, d) is a compact metric space;

(ii) the function

$$F \rightarrow \text{Min}(F, A, \varphi, u_0) = \min_u \left\{ F(u, A) + \int_A \varphi u \, dx : u - u_0 \in W_0^{1,\alpha}(A) \right\}$$

is (uniformly) continuous on (\mathcal{F}, d) , whenever A is an open bounded subset of \mathbf{R}^n , $\varphi \in L^\alpha(A)$ and $u_0 \in W^{1,\alpha}(A)$.

Let us remark that conditions (i) and (ii) depend on the fact that the convergence in \mathcal{F} is equivalent to the I -convergence, in the sense of E. DE GIORGI (see [7]).

Condition (i) says that (\mathcal{F}, d) is a good setting for the standard methods of Probability Theory. Condition (ii) implies that the convergence in probability of a sequence $(F_h(\omega))$ of random integral functionals toward $F_\infty(\omega)$ yields directly the convergence in probability of the respective random minima $\text{Min}(F_h(\omega), A, \varphi, u_0)$ to $\text{Min}(F_\infty(\omega), A, \varphi, u_0)$.

Of course, if we want to obtain the convergence in probability of the solutions

of Euler equations of $F_h(\omega)$ (in the case $F_h(\omega)$ are differentiable), we have to prove also the « continuity » of the minimizers (minimum points) but, in lack of uniqueness, this is more complicated to be explained briefly and so we refer to corollary 1.23.

The main result we prove is the following. Let $F, F_\varepsilon: \Omega \rightarrow \mathcal{F}$ ($\varepsilon > 0$) be random integral functionals and denote respectively by $f(\omega, x, p)$ and $f_\varepsilon(\omega, x, p)$ their integrands. For every $z \in \mathbf{Z}^n$ and $\varepsilon > 0$ let us define the random integral functionals $\tau_z F, \varrho_\varepsilon F: \Omega \rightarrow \mathcal{F}$ by

$$(\tau_z F)(\omega)(u, A) = \int_A f(\omega, x + z, Du(x)) dx$$

$$(\varrho_\varepsilon F)(\omega)(u, A) = \int_A f\left(\omega, \frac{x}{\varepsilon}, Du(x)\right) dx.$$

We say that F is stochastically 1-periodic if $\tau_z F \sim F$ for every $z \in \mathbf{Z}^n$ where \sim means for us to have the same distribution law. We say that (F_ε) is a stochastic homogenization process modelled on F if $F_\varepsilon \sim \varrho_\varepsilon F$ for every $\varepsilon > 0$.

MAIN THEOREM. - *Let (F_ε) be a stochastic homogenization process modelled on a stochastically 1-periodic functional F . Suppose that there exists $M > 0$ such that, whenever A, B are disjoint bounded open subsets of \mathbf{R}^n with $\text{dist}(A, B) \geq M$, the two families of random functions*

$$\omega \rightarrow (F(\omega)(u, A))_{u \in U} \quad \text{and} \quad \omega \rightarrow (F(\omega)(u, B))_{u \in U}$$

are independent.

Then there exists a single functional $F_0 \in \mathcal{F}$ (or equivalently a constant random integral functional) such that (F_ε) converges in probability to F_0 as $\varepsilon \rightarrow 0^+$. Moreover the integrand $f_0(x, p)$ of F_0 does not depend on x and

$$(2) \quad f_0(p) = \lim_{\varepsilon \rightarrow 0^+} \int_{\Omega} \frac{1}{|Q_{1/\varepsilon}|} \text{Min} (F(\omega), Q_{1/\varepsilon}, 0, l_p) dP(\omega)$$

where $Q_{1/\varepsilon} = \{x \in \mathbf{R}^n: |x_i| < 1/\varepsilon, i = 1, \dots, n\}$ is a cube, $|Q_{1/\varepsilon}|$ is its Lebesgue measure, $l_p(x) = p \cdot x$ is the linear function with gradient p , and P is the probability on Ω .

In order to grasp better this result, let us anticipate from the fourth section of this paper a very simple one-dimensional example. For every $\varepsilon > 0$ let us consider a wire formed by small segments of length ε of two different materials randomly chosen, having thermal conductivities $\lambda > 0, \Lambda > 0$.

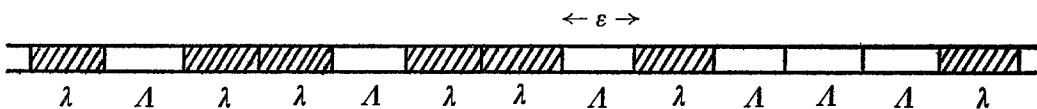

Fig. 1.

The thermal energy of a piece A of this wire, corresponding to a temperature distribution u , is

$$F_\varepsilon(\omega)(u, A) = \int_A a_\varepsilon(\omega, t) u'(t)^2 dt$$

where the generic random parameter ω is a sequence $(\omega_n)_{n \in \mathbf{Z}}$ with values λ, A and

$$a_\varepsilon(\omega, t) = \omega_k \quad \text{if } t \in [k\varepsilon, (k+1)\varepsilon[, \quad k \in \mathbf{Z}.$$

Then we may choose $\Omega = \{\lambda, A\}^{\mathbf{Z}}$ and the probability P equal to the infinite product of the trivial equi-distributed probability on $\{\lambda, A\}$. Let $F = F_1$; as $a_1(\omega, t+j) = a_1(\tilde{\omega}, t)$ with $\tilde{\omega}_n = \omega_{n+j}$, then $\tau_j F$ has the same distribution law of F for every $j \in \mathbf{Z}$. Moreover $\rho_\varepsilon F = F_\varepsilon$. Finally, if $\text{dist}(A, B) \geq 1$, $F(\omega)(u, A)$ and $F(\omega)(u, B)$ are independent because, roughly speaking, no unitary segment intersect both A and B , hence the values of the energies on A and on B are independent.

Applying our theorem we obtain that there exists

$$F_0(u, A) = \int_A f_0(u'(t)) dt$$

such that (F_ε) converges in probability to F_0 . Calculating f_0 by (2), we have that $f_0(p) = cp^2$ with c the harmonic mean of λ and A . This shows that in this case the homogeneous material after the stochastic homogenization is the same as after the classical homogenization in which the two materials are regularly alternated without randomness. Moreover, in this particular case, one could prove directly that actually $(F_\varepsilon(\omega))$ converges to F_0 (in the sense of \mathcal{F} , or Γ -converges) for P -almost all $\omega \in \Omega$, because in dimension one there is a good characterization for the Γ -convergence of the integral quadratic forms.

Let us return to our main theorem, by doing some remarks.

(a) Our hypotheses concern only the distribution laws of $F, \tau_\varepsilon F, F_\varepsilon, \rho_\varepsilon F$ so obviously we can not obtain the almost sure convergence of (F_ε) to F_0 . However, if we suppose $\rho_\varepsilon F = F_\varepsilon$ instead of $\rho_\varepsilon F \sim F_\varepsilon$, it remains open the question of the almost sure convergence, which is verified in the example quoted above, in an example studied by G. FACCHINETTI and L. RUSSO [11] and in the case (1) of second order elliptic equations.

(b) Our proof relies essentially on De Giorgi's Γ -convergence Theory (under this aspect the paper is self-contained) and on elementary Probability Theory. In particular, we do not use explicitly Ergodic Theory.

(c) Actually, the crucial hypothesis of independence of $F(\omega)(u, A)$ and $F(\omega)(u, B)$ for $\text{dist}(A, B) \geq M$ might be relaxed in a kind of asymptotic uncorrelation but it should become less readable and more complicated to be verified in the examples,

so we have preferred in this paper to consider a stronger but simpler hypothesis. Depending on this, we can not attack directly here, for instance, the case of homogenization of chessboard structures with cells of completely random size (the figure

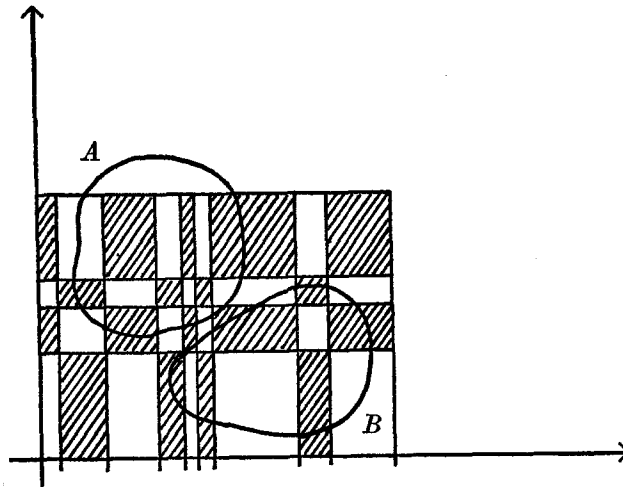

Fig. 2.

below should be a hint to understanding it) but only with cells whose random size is estimated a priori from above. Let us recall that the one-dimensional case of homogenization with cells of completely random size, proposed by E. DE GIORGI, was the starting point of this research (see L. MODICA [17]) and has been solved by G. FACCHINETTI and L. RUSSO [11].

The plan of the paper is the following.

1. - Integral functionals and Γ -convergence.
2. - Random integral functionals.
3. - Main results.
4. - Examples:
 - 4.1. Homogenization with regular cells occupied by two materials randomly chosen;
 - 4.2. Homogenization with cells of bounded random size alternatively occupied by two materials.

1. - Integral functionals and Γ -convergence.

In this section we introduce the class of integral functionals we shall deal with in the rest of the paper and we endow it with a topological structure related to the

Γ -convergence. All the results we state here are substantially known but they are often not easily available in the literature, so we prefer to give the proofs.

Let \mathcal{A}_0 be the family of all bounded open subsets of \mathbf{R}^n and fix three real constants c_1, c_2, α such that $0 < c_1 \leq c_2$ and $\alpha > 1$. These constants will be held fixed throughout the paper, so we often omit to indicate explicitly the dependence on c_1, c_2, α .

We denote by $\mathcal{F} = \mathcal{F}(c_1, c_2, \alpha)$ the class of all functionals $F: L^\alpha_{loc}(\mathbf{R}^n) \times \mathcal{A}_0 \rightarrow \overline{\mathbf{R}} = \mathbf{R} \cup \{+\infty, -\infty\}$ such that

$$(3) \quad F(u, A) = \begin{cases} \int_A f(x, Du(x)) \, dx & \text{if } u|_A \in W^{1,\alpha}(A) \\ +\infty & \text{otherwise} \end{cases}$$

where $f: \mathbf{R}^n \times \mathbf{R}^n \rightarrow \mathbf{R}$ is any function satisfying the following conditions:

$$(4) \quad f(x, p) \text{ is Lebesgue measurable in } x \text{ and convex in } p;$$

$$(5) \quad c_1|p|^\alpha \leq f(x, p) \leq c_2(|p|^\alpha + 1), \quad \forall (x, p) \in \mathbf{R}^n \times \mathbf{R}^n.$$

We shall refer to the left-hand side inequality in (5) as the equicoerciveness of the elements of \mathcal{F} and to the right-hand side inequality as the equiboundedness of the elements of \mathcal{F} .

As usual, $Du = (\partial u/\partial x_1, \dots, \partial u/\partial x_n)$ denotes the gradient of u and $W^{1,\alpha}(A)$ denotes the Sobolev space of the functions of $L^\alpha(A)$ whose first weak derivatives belong to $L^\alpha(A)$. We shall denote by $W^{1,\alpha}_0(A)$ the closure of $C^\infty_0(A)$ in $W^{1,\alpha}(A)$.

Note that, if $u \in W^{1,\alpha}(A)$, the function $x \rightarrow f(x, Du(x))$ is non-negative and Lebesgue measurable on A (recall that $f(x, p)$ is convex in p) so the integral in (3) makes sense.

Actually, (3) defines $F(u, A)$ for every $u \in L^\alpha_{loc}(A)$ (or also $u \in L^1_{loc}(A)$) even if u can not be extended to \mathbf{R}^n as an element of $L^\alpha_{loc}(\mathbf{R}^n)$: for technical reasons, we prefer not to take into consideration this case in the definition of F .

There is not this problem when $u \in L^\alpha(A)$: in this case we may extend u to an element \tilde{u} of $L^\alpha_{loc}(\mathbf{R}^n)$ and the value of $F(\tilde{u}, A)$ does not depend on the extension \tilde{u} of u . So, each $F \in \mathcal{F}$ defines, for every $A \in \mathcal{A}_0$, a functional $F_A: L^\alpha(A) \rightarrow \overline{\mathbf{R}}$.

1.1. REMARK. - If $F \in \mathcal{F}$, the integrand $f(x, p)$ of F is identified for almost all $x \in \mathbf{R}^n$ and for all $p \in \mathbf{R}^n$. Indeed, if $B_\varrho(x)$ is the ball in \mathbf{R}^n with center in x and radius ϱ , $|B_\varrho(x)|$ is its Lebesgue measure and $l_p: \mathbf{R}^n \rightarrow \mathbf{R}$ is the linear function with gradient p , we have

$$\lim_{\varrho \rightarrow 0^+} \frac{1}{|B_\varrho(x)|} F(l_p, B_\varrho) = f(x, p) \quad \text{for a.a. } x \in \mathbf{R}^n.$$

We say that a subfamily \mathcal{B} of \mathcal{A}_0 is dense if, for every $A_1, A_2 \in \mathcal{A}_0$ with $A_1 \subset\subset A_2$ ($A \subset\subset B$ means $\bar{A} \subset B$), there exists $B \in \mathcal{B}$ such that $A_1 \subset\subset B \subset\subset A_2$.

1.2. PROPOSITION. - *Suppose \mathfrak{B} is a dense subfamily of \mathcal{A}_0 . Then*

$$F(u, A) = \sup \{F(u, B) : B \in \mathfrak{B}, B \subseteq A\}$$

for every $F \in \mathcal{F}$, $u \in L^{\alpha}_{loc}(\mathbf{R}^n)$, $A \in \mathcal{A}_0$

PROOF - Trivial (if $u \notin W^{1,\alpha}(A)$, because of equicoerciveness (5)).

1.3. PROPOSITION (Rellich's Theorem). - *Let $A \in \mathcal{A}_0$. Then any bounded subset of $W^{1,\alpha}_0(A)$ is relatively compact in $L^{\alpha}(A)$. If, in addition, the boundary of A is Lipschitz continuous, then any bounded subset of $W^{1,\alpha}(A)$ is relatively compact in $L^{\alpha}(A)$.*

PROOF. - See e.g. [22], sect. 25-26.

1.4. COROLLARY. - *Let $A \in \mathcal{A}_0$. Then any bounded sequence in $W^{1,\alpha}(A)$ contains a subsequence that converges in $L^{\alpha}_{loc}(A)$, weakly in $W^{1,\alpha}(A)$ and pointwise almost everywhere in A .*

PROOF. - It follows from Rellich's theorem recalling that $W^{1,\alpha}(A)$ is reflexive because $\alpha > 1$ and that any convergent sequence in $L^{\alpha}_{loc}(A)$ contains a subsequence which converges pointwise almost everywhere in A .

1.5. PROPOSITION. - *Let $A \in \mathcal{A}_0$ and $F \in \mathcal{F}$. Then the functional F_A is lower semicontinuous in $L^{\alpha}(A)$. Moreover, its restriction to $W^{1,\alpha}(A)$ is continuous in the strong topology of $W^{1,\alpha}(A)$ and lower semicontinuous in the weak topology of $W^{1,\alpha}(A)$.*

PROOF. - The strong continuity of F_A in $W^{1,\alpha}(A)$ follows from convexity and equiboundedness (5) (e.g. see [9], ch. 1, prop. 2.5). The weak lower semicontinuity of F_A in $W^{1,\alpha}(A)$ follows from convexity and strong continuity (e.g. see [9], ch. 1, cor. 2.2). Now, let us prove the lower semicontinuity in $L^{\alpha}(A)$, that is

$$(6) \quad F_A(u_{\infty}) \leq \liminf_{h \rightarrow +\infty} F_A(u_h)$$

for every sequence (u_h) converging in $L^{\alpha}(A)$ to u_{∞} . It is not restrictive to assume that $(F_A(u_h))$ is bounded, so equicoerciveness (5) gives that (Du_h) is bounded in $L^{\alpha}(A)$. On the other hand (u_h) converges to u_{∞} in $L^{\alpha}(A)$, hence corollary 1.4 implies that (u_h) converges to u_{∞} weakly in $W^{1,\alpha}(A)$. Then (6) follows from the weak lower semicontinuity of F_A in $W^{1,\alpha}(A)$.

1.6. COROLLARY. - *Let \mathcal{W} be a dense subset of $W^{1,\alpha}(\mathbf{R}^n)$ and \mathfrak{B} a dense subfamily of \mathcal{A}_0 . If $F, G \in \mathcal{F}$ and*

$$F(w, B) = G(w, B), \quad \forall w \in \mathcal{W}, \forall B \in \mathfrak{B},$$

then $F = G$.

PROOF. - It follows from propositions 1.2 and 1.5, because $W^{1,\alpha}(\mathbf{R}^n)$ is dense in $W^{1,\alpha}(A)$ for every $A \in \mathcal{A}_0$ with Lipschitz continuous boundary and the family of all these open sets is dense in \mathcal{A}_0 .

For $A \in \mathcal{A}_0$, denote by P_A the best constant in the Poincaré inequality (see e.g. [22], sect. 23, ineq. (23.5))

$$(7) \quad \int_A |u|^\alpha dx \leq P_A \int_A |Du|^\alpha dx, \quad \forall u \in W_0^{1,\alpha}(A).$$

1.7. PROPOSITION. - Let $A \in \mathcal{A}_0$ and $F \in \mathcal{F}$. Suppose X is a nonvoid weakly closed subset of $W^{1,\alpha}(A)$ and $\varphi: A \times \mathbf{R} \rightarrow \mathbf{R}$ is a function such that $\varphi(x, y)$ is Lebesgue measurable in x and continuous in y . If

$$(8) \quad \varphi(x, y) \geq \lambda |y|^\alpha + \mu(x), \quad \forall (x, y) \in A \times \mathbf{R}$$

for some $\lambda > 0$ and $\mu \in L^1(A)$, then there exists the minimum in X of the functional $\Psi: L^\alpha(A) \rightarrow \mathbf{R}$ defined by

$$\Psi(u) = F_A(u) + \int_A \varphi(x, u(x)) dx.$$

If $X \subseteq u_0 + W_0^{1,\alpha}(A)$ for some $u_0 \in W^{1,\alpha}(A)$, then (8) may be relaxed by requiring only $\lambda > -c_1/P_A$.

PROOF. - First, suppose $\lambda > 0$. By (8) and equicoerciveness (5), we have that

$$(9) \quad \Psi(u) \geq \min \{c_1, \lambda\} \|u\|_{W^{1,\alpha}(A)}^\alpha - \|\mu\|_{L^1(A)}, \quad \forall u \in X$$

hence $m = \inf_{u \in X} \Psi(u) > -\infty$. Since the case $m = +\infty$ is trivial, we assume that $m \in \mathbf{R}$ and we choose a minimizing sequence (u_n) in X such that $(\Psi(u_n))$ is bounded. Then we infer from (9) that (u_n) is bounded in $W^{1,\alpha}(A)$ and, applying corollary 1.4, we may select a subsequence $(u_{\sigma(n)})$ that converges weakly in $W^{1,\alpha}(A)$ and pointwise almost everywhere to a function $u_\infty \in W^{1,\alpha}(A)$. We claim that u_∞ is the minimum point of Ψ in X . In fact, $u_\infty \in X$ because X is weakly closed and, by proposition 1.5, we have that

$$F_A(u_\infty) \leq \liminf_{h \rightarrow +\infty} F_A(u_{\sigma(h)}).$$

On the other hand, pointwise almost everywhere convergence, Fatou's lemma and (8) give that

$$\int_A \varphi(x, u_\infty(x)) dx \leq \liminf_{h \rightarrow +\infty} \int_A \varphi(x, u_{\sigma(h)}(x)) dx.$$

Then, we conclude that

$$m \leq \mathcal{P}(u_\infty) = \int_A \varphi(x, u_\infty(x)) \, dx \leq \liminf_{h \rightarrow +\infty} \mathcal{P}(u_{\sigma(h)}) = m$$

and the proposition is proved.

In the case $X \subseteq u_0 + W_0^{1,\alpha}(A)$ and $\lambda > -c_1/P_A$, (9) may be replaced by

$$(9') \quad \mathcal{P}(u) \geq k_1 \|u\|_{W^{1,\alpha}(A)}^\alpha - k_2 \|u_0\|_{W^{1,\alpha}(A)}^\alpha - \|\mu\|_{L^1(A)}, \quad \forall u \in X$$

where $k_1 > 0$ and $k_2 > 0$ are suitable real constants. Indeed, by Poincaré inequality we obtain that

$$\|u - u_0\|_{L^\alpha(A)}^\alpha \leq P_A \|Du - Du_0\|_{L^\alpha(A)}^\alpha \leq P_A (|Du| + |Du_0|)_{L^\alpha(A)}^\alpha$$

hence, by convexity

$$\begin{aligned} \|u\|_{L^\alpha(A)}^\alpha &\leq (1 - \varepsilon)^{1-\alpha} \|u - u_0\|_{L^\alpha(A)}^\alpha + \varepsilon^{1-\alpha} \|u_0\|_{L^\alpha(A)}^\alpha \leq \\ &\leq (1 - \varepsilon)^{1-\alpha} P_A (|Du| + |Du_0|)_{L^\alpha(A)}^\alpha + \varepsilon^{1-\alpha} \|u_0\|_{L^\alpha(A)}^\alpha \leq \\ &\leq (1 - \varepsilon)^{2-2\alpha} P_A \|Du\|_{L^\alpha(A)}^\alpha + (1 - \varepsilon)^{1-\alpha} P_A \varepsilon^{1-\alpha} \|Du_0\|_{L^\alpha(A)}^\alpha + \varepsilon^{1-\alpha} \|u_0\|_{L^\alpha(A)}^\alpha \end{aligned}$$

for every $u \in X$ and for every $\varepsilon \in]0, 1[$. Now, by (8)

$$\begin{aligned} \mathcal{P}(u) &\geq c_1 \|Du\|_{L^\alpha(A)}^\alpha + \lambda \|u\|_{L^\alpha(A)}^\alpha - \|\mu\|_{L^1(A)} = \\ &= \delta \|Du\|_{L^\alpha(A)}^\alpha + (c_1 - \delta) \|Du\|_{L^\alpha(A)}^\alpha + \lambda \|u\|_{L^\alpha(A)}^\alpha - \|\mu\|_{L^1(A)} \geq \\ &\geq \delta \|Du\|_{L^\alpha(A)}^\alpha + \left[(c_1 - \delta) \frac{(1 - \varepsilon)^{2\alpha-2}}{P_A} + \lambda \right] \|u\|_{L^\alpha(A)}^\alpha - \\ &- (c_1 - \delta) (1 - \varepsilon)^{\alpha-1} \varepsilon^{1-\alpha} \|Du_0\|_{L^\alpha(A)}^\alpha - (c_1 - \delta) \frac{\varepsilon^{1-\alpha}}{P_A} (1 - \varepsilon)^{2\alpha-2} \|u_0\|_{L^\alpha(A)}^\alpha - \|\mu\|_{L^1(A)} \end{aligned}$$

for every $u \in X$, $\varepsilon \in]0, 1[$, $\delta \in]0, c_1[$. Recalling that $c_1/P_A + \lambda > 0$, we may choose ε and δ small enough so that $(c_1 - \delta)(1 - \varepsilon)^{2\alpha-2}/P_A + \lambda > 0$ and (9') is proved. Moreover, the above subsequence $(u_{\sigma(h)})$ may be selected so that $(u_{\sigma(h)})$ converges also in $L^\alpha(A)$ (Rellich's theorem, see proposition 1.3) so, by Fatou's lemma applied to $\varphi(x, u_{\sigma(h)}(x)) - \lambda |u_{\sigma(h)}(x)|^\alpha$

$$\liminf_{h \rightarrow +\infty} \int_A \varphi(x, u_{\sigma(h)}(x)) \, dx \geq \int_A \varphi(x, u_\infty(x)) \, dx$$

and the proof of this case is equal to the previous one.

1.8. REMARK. - In the case $X \subseteq u_0 + W^{1,\alpha}(A)$, (8) is verified for some $\lambda > -c_1/P_A$ if $\varphi(x, y) \geq \chi(x)|y|^\beta$ with $1 < \beta < \alpha$, $\chi \in L^\gamma(A)$ and γ equals the dual exponent of α/β . In fact, the elementary inequality

$$ab \leq \frac{1}{p\varepsilon^p} a^p + \frac{\varepsilon^q}{q} b^q \quad \left(a, b, \varepsilon, p, q > 0, \frac{1}{p} + \frac{1}{q} = 1 \right)$$

yields

$$\chi(x)|y|^\beta \geq -\varepsilon^{\alpha/\beta}|y|^\alpha - \frac{1}{\varepsilon^\gamma} |\chi(x)|^\gamma, \quad \forall (x, y) \in A \times \mathbf{R}^n, \forall \varepsilon > 0$$

so it suffices to choose ε so small that $-\varepsilon^{\alpha/\beta} > -c_1/P_A$.

1.9. EXAMPLES. - When $\alpha = 2$ proposition 1.7 applies in these well-known cases:

(a) $X = W^{1,2}(A)$, $f(x, p) = |p|^2$, $\varphi(x, y) = \lambda|y - u_1(x)|^2$, $\lambda > 0$, $u_1 \in L^2(A)$: here the minimum point of Ψ in X is the weak solution in $W^{1,2}(A)$ of the Neumann problem for the equation $\Delta u = \lambda(u - u_1)$.

(b) $X = u_0 + W_0^{1,2}(A)$, $f(x, p) = \sum_{i,j=1}^n a_{ij}(x)p_i p_j$, satisfying (4), (5) and $a_{ij} = a_{ji}$, $\varphi(x, y) = 2y\chi(x)$, $\chi \in L^2(A)$: here the minimum point of Ψ is the weak solution in $W^{1,2}(A)$ of the Dirichlet problem for the equation $\sum_{i,j=1}^n D_i(a_{ij} D_j u) = \chi$ with prescribed boundary value u_0 .

(c) $X = W_0^{1,2}(A)$, $f(x, p)$ as above in (b), $\varphi(x, y) = -ky^2 + 2y\chi(x)$, $0 < k < c_1/P_A$: here the minimum point is the unique weak solution in $W_0^{1,2}(A)$ of the Dirichlet problem for the equation

$$\sum_{i,j=1}^n D_i(a_{ij} D_j u) + ku = \chi$$

(the uniqueness depends on the fact that k is smaller than the first eigenvalue of $c_1 \Delta$).

In these examples $\varphi(x, y)$ is smooth in y so we can consider the Euler equation of Ψ , but note that proposition 1.7 applies also to non-smooth φ .

In order to give a topological structure on \mathcal{F} , we need the definition of ε -Yosida transform of a functional $F \in \mathcal{F}$.

For every $F \in \mathcal{F}$ and $\varepsilon > 0$, the ε -Yosida transform of F is the function $T_\varepsilon F: L_{loc}^\alpha(\mathbf{R}^n) \times \mathcal{A}_0 \rightarrow \mathbf{R}$ defined by

$$(10) \quad T_\varepsilon F(u, A) = \inf \left\{ F(v, A) + \frac{1}{\varepsilon} \int_A |v - u|^\alpha dx : v \in L_{loc}^\alpha(\mathbf{R}^n) \right\}$$

or also, by proposition 1.7

$$(10') \quad T_\varepsilon F(u, A) = \min \left\{ F_A(v) + \frac{1}{\varepsilon} \int_A |v - u|^\alpha dx : v \in W^{1,\alpha}(A) \right\}.$$

This kind of transform was considered for generic functions on metric spaces in [7] (except for a slight unessential difference), motivated by the methods occurring in [8]; it is strictly related with the Fenchel-Moreau conjugation (see [9], ch. I). The name « Yosida transform » comes from the following remark.

1.10. REMARK. - Let $\alpha = 2$ and $f(x, p) = \sum_{i,j=1}^n a_{ij}(x) p_i p_j$ satisfying (4), (5) and $a_{ij} = a_{ji}$. By forgetting for a moment that $\mathbf{R}^n \notin \mathcal{A}_0$, we calculate $F(u, \mathbf{R}^n)$ obtaining

$$F(u, \mathbf{R}^n) = \langle Lu, u \rangle, \quad \forall u \in W^{1,2}(\mathbf{R}^n) = H_0^{1,2}(\mathbf{R}^n)$$

where $L = - \sum_{i,j=1}^n D_i(a_{ij} D_j): H_0^{1,2}(\mathbf{R}^n) \rightarrow H^{-1,2}(\mathbf{R}^n)$ and $\langle \cdot, \cdot \rangle$ is the pairing between $H^{-1,2}(\mathbf{R}^n)$ and $H_0^{1,2}(\mathbf{R}^n)$. Now we shall show that

$$T_\varepsilon F(u, \mathbf{R}^n) = \langle L^{(\varepsilon)} u, u \rangle, \quad \forall u \in H_0^{1,2}(\mathbf{R}^n)$$

where $L^{(\varepsilon)} = 1/\varepsilon [I - I(I + \varepsilon L)^{-1} I] = L(I + \varepsilon L)^{-1} I$ is the Yosida ε -approximation of L (e.g. see [2], pg. 28) and I is the natural embedding of $H_0^{1,2}(\mathbf{R}^n)$ into $H^{-1,2}(\mathbf{R}^n)$. In fact

$$T_\varepsilon F(u, \mathbf{R}^n) = F(v_\varepsilon, \mathbf{R}^n) + \frac{1}{\varepsilon} \int_{\mathbf{R}^n} |v_\varepsilon - u|^2 dx$$

where v_ε is the solution in $H_0^{1,2}(\mathbf{R}^n)$ of

$$Lv_\varepsilon + \frac{1}{\varepsilon} I(v_\varepsilon - u) = 0.$$

From the last equation we infer that

$$v_\varepsilon = (I + \varepsilon L)^{-1} Iu$$

hence

$$\begin{aligned} F(v_\varepsilon, \mathbf{R}^n) + \frac{1}{\varepsilon} \int_{\mathbf{R}^n} |v_\varepsilon - u|^2 dx &= \langle Lv_\varepsilon, v_\varepsilon \rangle + \left\langle \frac{1}{\varepsilon} I(v_\varepsilon - u), v_\varepsilon - u \right\rangle = \\ &= \langle Lv_\varepsilon, v_\varepsilon \rangle - \langle Lv_\varepsilon, v_\varepsilon - u \rangle = \langle Lv_\varepsilon, u \rangle = \langle L^{(\varepsilon)} u, u \rangle. \end{aligned}$$

1.11. PROPOSITION. - Let $F \in \mathcal{F}$, $u \in L_{loc}^\infty(\mathbf{R}^n)$, $A \in \mathcal{A}_0$. Then

$$\lim_{\varepsilon \rightarrow 0^+} T_\varepsilon F(u, A) = \sup_{\varepsilon > 0} T_\varepsilon F(u, A) = F(u, A).$$

PROOF. - It is obvious that $T_\varepsilon F(u, A)$ is non-increasing in ε and bounded from above by $F(u, A)$, hence it suffices to prove that for every $k < F(u, A)$ there exists

$\varepsilon > 0$ such that $T_\varepsilon F(u, A) \geq k$. Fix $k < F(u, A)$. By lower semicontinuity (proposition 1.5) there exists $\delta > 0$ such that

$$F(v, A) > k, \quad \forall v \in L^\alpha(A): \int_A |v - u|^\alpha dx < \delta$$

therefore, for these functions v

$$F(v, A) + \frac{1}{\varepsilon} \int_A |v - u|^\alpha dx > k, \quad \forall \varepsilon > 0.$$

On the other hand, if $v \in L^\alpha(A)$ and $\int_A |v - u|^\alpha dx \geq \delta$, then

$$F(v, A) + \frac{1}{\varepsilon} \int_A |v - u|^\alpha dx \geq \frac{\delta}{\varepsilon}, \quad \forall \varepsilon > 0$$

hence

$$T_\varepsilon F(u, A) \geq \min \left\{ k, \frac{\delta}{\varepsilon} \right\} = k$$

for ε small enough.

Now, we define a distance on \mathcal{F} . Let us choose a countable dense subset $\mathcal{W} = \{w_j: j \in \mathbf{N}\}$ of $W^{1,\alpha}(\mathbf{R}^n)$ and a countable dense subfamily $\mathcal{B} = \{B_k: k \in \mathbf{N}\}$ of \mathcal{A}_0 . For instance, \mathcal{B} could be chosen as the family of all bounded open subsets of \mathbf{R}^n which are finite unions of rectangles with rational vertices. Let us define for $F, G \in \mathcal{F}$

$$(11) \quad d(F, G) = \sum_{i,j,k=1}^{+\infty} \frac{1}{2^{i+j+k}} |\text{arc tg } T_{1/i} F(w_j, B_k) - \text{arc tg } T_{1/i} G(w_j, B_k)|.$$

1.12. PROPOSITION. - d is a distance on \mathcal{F} .

PROOF. - If $d(F, G) = 0$, then proposition 1.11 and corollary 1.6 give that $F = G$. The other properties of a distance are straightforward to prove.

1.13. REMARK. - By changing \mathcal{W} and \mathcal{B} one may obtain different distances but all of them are topologically equivalent to d : this will be a consequence of proposition 1.21. Moreover, it is obvious that in (11) arctg may be replaced by any increasing, continuous, bounded function $\chi: \mathbf{R} \rightarrow \mathbf{R}$.

The main reason for choosing d as distance on \mathcal{F} is the link between d and Γ -convergence, a type of variational convergence proposed by E. DE GIORGI and studied by many authors in the last years (see the bibliography of [6]). Let us define the case of Γ -convergence we are interested in.

Let X be a metric space and let (F_λ) be a sequence of functions defined on X with values in $\overline{\mathbf{R}}$. We say that (F_λ) $\Gamma(X^-)$ converges at a point $x_\infty \in X$ to $\lambda \in \overline{\mathbf{R}}$ if

the following two conditions are fulfilled:

$$(12) \quad \lambda \leq \liminf_{h \rightarrow +\infty} F_h(x_h)$$

for any sequence (x_h) converging in X to x_∞ ;

(13) there exists a sequence (x_h) converging in X to x_∞ such that

$$\limsup_{h \rightarrow +\infty} F_h(x_h) \leq \lambda.$$

In this case we write $\lambda = \Gamma(X^-) \lim_{h \rightarrow +\infty} F_h(x_\infty)$. If there exists $F_\infty: X \rightarrow \bar{\mathbf{R}}$ such that

$$F_\infty(x) = \Gamma(X^-) \lim_{h \rightarrow +\infty} F_h(x), \quad \forall x \in X$$

we say that $(F_h) \Gamma(X^-)$ converges to F_∞ . Note that, in this last case, (12) and (13) give that

$$(14) \quad F_\infty(x_\infty) = \min \left\{ \liminf_{h \rightarrow +\infty} F_h(x_h) : (x_h) \text{ converging in } X \text{ to } x_\infty \right\}$$

for every $x_\infty \in X$, hence they determine univocally the $\Gamma(X^-)$ limit F_∞ .

For technical reasons, it will be useful to have the following equivalent formulation of (13).

1.14. PROPOSITION. - *The condition (13) is equivalent to:*

$$(13') \quad \limsup_{h \rightarrow +\infty} \left[\inf_{x \in U} F_h(x) \right] \leq \lambda$$

for any neighborhood U of x_∞ .

PROOF. - It is trivial that (13) implies (13'). Conversely, suppose (13') holds and denote by U_k the ball in X with center x_∞ and radius $1/k$. Then there exists an increasing function $\sigma: \mathbf{N} \rightarrow \mathbf{N}$ such that

$$\inf_{x \in U_k} F_h(x) \leq \lambda + \frac{1}{2k}, \quad \forall h, k \in \mathbf{N}: h \geq \sigma(k)$$

therefore we may select $y_{h,k} \in U_k$ such that

$$F_h(y_{h,k}) \leq \lambda + \frac{1}{k}, \quad \forall h, k \in \mathbf{N}: h \geq \sigma(k).$$

Let $\tau: \mathbf{N} \rightarrow \mathbf{N}$ the « inverse function » of σ , that is

$$\tau(h) = \min \{ j \in \mathbf{N}: \sigma(j+1) > h \}$$

and define $x_h = y_{h,\tau(h)}$. Then

$$\sigma(\tau(h)) \leq h, \quad x_h \in U_{\tau(h)}, \quad \lim_{h \rightarrow +\infty} \tau(h) = +\infty \quad \text{and} \quad F_h(x_h) \leq \lambda + \frac{1}{\tau(h)}$$

so (x_h) converges in X to x_∞ and (13) holds.

1.15. PROPOSITION. - *Let (F_h) be a sequence of functions defined on a metric space X with values in $\overline{\mathbf{R}}$.*

(a) *If $F_h = F$ for every $h \in \mathbf{N}$ and F is lower semicontinuous in X , then $(F_h) \Gamma(X^-)$ converges to F .*

(b) *If the sequence $(F_h) \Gamma(X^-)$ converges to a function F_∞ , then any subsequence $\Gamma(X^-)$ converges to F_∞ .*

(c) *If the sequence (F_h) does not $\Gamma(X^-)$ converge to a function $F_\infty: X \rightarrow \overline{\mathbf{R}}$, then there exists a subsequence $(F_{\sigma(h)})$ of (F_h) with the property that no further subsequence of $(F_{\sigma(h)}) \Gamma(X^-)$ converges to F_∞ .*

PROOF. - (a) and (b) follow directly from the definition (12), (13) of $\Gamma(X^-)$ convergence. For (c) note that, if (F_h) does not $\Gamma(X^-)$ converge to F_∞ , either (12) or (13') are not satisfied. In both cases it is immediate to construct a subsequence of (F_h) such that no further subsequence satisfies respectively (12) or (13'), so the proposition is proved.

1.16. REMARK. - Proposition 1.15 says that the set of the lower semicontinuous functions defined on X with values in $\overline{\mathbf{R}}$, endowed with the $\Gamma(X^-)$ convergence, is a \mathcal{L}^* -space in the terminology of K. KURATOWSKI ([14], vol. I, ch. 2, § 20).

Now, let us adapt the definition of Γ -convergence for sequences of functionals in \mathcal{F} . We say that a sequence (F_h) in $\mathcal{F} \Gamma(L^{\alpha^-})$ converges (or simply Γ -converges) to a functional $F_\infty \in \mathcal{F}$ if

$$\Gamma(L^\alpha(A)^-) \lim_{h \rightarrow +\infty} (F_h)_A(u) = (F_\infty)_A(u), \quad \forall u \in L^\alpha(A)$$

whenever $A \in \mathcal{A}_0$. In this case we write $\Gamma(L^{\alpha^-}) \lim_{h \rightarrow +\infty} F_h = F_\infty$.

The next propositions give the main properties of $\Gamma(L^{\alpha^-})$ convergence in \mathcal{F} : compactness (1.17-1.22), convergence of minima and minimizers (1.18-1.19), link with the distance d (1.21), continuity of the ε -Yosida transform, of minima and minimizers (1.23-1.25).

1.17. PROPOSITION. - *The class \mathcal{F} is compact for the $\Gamma(L^{\alpha^-})$ convergence, in the sense that every sequence (F_h) in \mathcal{F} contains a subsequence that $\Gamma(L^{\alpha^-})$ converges to a functional $F_\infty \in \mathcal{F}$.*

PROOF. – Let (F_h) be a sequence in \mathcal{F} . By theorems 4.3 and 2.4 of [4] (with some minor changes in the proofs) there exists a subsequence $(F_{\sigma(h)})$ and a function $f_\infty: \mathbf{R}^n \times \mathbf{R}^n \rightarrow \mathbf{R}$, non-negative, Lebesgue measurable in the first n variables, convex in the last n variables such that

$$(15) \quad \Gamma(L^\alpha(A)^-) \lim_{h \rightarrow +\infty} (F_{\sigma(h)})_A(u) = \int_A f_\infty(x, Du(x)) \, dx$$

for every $A \in \mathcal{A}_0$ and $u \in W^{1,\alpha}(A)$. If $u \in L^\alpha(A) \setminus W^{1,\alpha}(A)$ and (u_h) is a sequence converging in $L^\alpha(A)$ to u , then (u_h) can not have bounded subsequences in $W^{1,\alpha}(A)$ by corollary 1.4. It follows that either $u_h \notin W^{1,\alpha}(A)$ definitively or

$$\lim_{h \rightarrow +\infty} \int_A |Du_{\tau(h)}|^\alpha \, dx = +\infty$$

for each subsequence $(u_{\tau(h)})$ contained in $W^{1,\alpha}(A)$.

In both cases, recalling (3) and (5), we obtain that

$$\liminf_{h \rightarrow +\infty} (F_{\sigma(h)})_A(u_h) = +\infty$$

hence

$$\Gamma(L^\alpha(A)^-) \lim_{h \rightarrow +\infty} (F_{\sigma(h)})_A(u) = \begin{cases} \int_A f_\infty(x, Du(x)) \, dx & \text{if } u \in W^{1,\alpha}(A) \\ +\infty & \text{if } u \in L^\alpha(A) \setminus W^{1,\alpha}(A) \end{cases}$$

for every $A \in \mathcal{A}_0$.

The right-hand side of the last equality defines a functional $F_\infty: L^\alpha_{loc}(\mathbf{R}^n) \times \mathcal{A}_0 \rightarrow \overline{\mathbf{R}}$ which is the $\Gamma(L^\alpha)$ limit of $(F_{\sigma(h)})$. It remains to prove that $F_\infty \in \mathcal{F}$, that is (5) holds. Indeed,

$$c_1 \int_A |Du|^\alpha \, dx \leq F_{\sigma(h)}(u, A) \leq c_2 \int_A (1 + |Du|^\alpha) \, dx$$

for every $A \in \mathcal{A}_0$, $u \in W^{1,\alpha}(A)$, $h \in \mathbf{N}$: by taking the $\Gamma(L^\alpha(A)^-)$ limit of these three terms as $h \rightarrow +\infty$, the first one and the last one do not change because of lower semicontinuity (propositions 1.5 and 1.15 (a)) and the double inequality continues to hold (Γ -convergence is « monotone ») by (14), so we obtain that

$$(16) \quad c_1 \int_A |Du|^\alpha \, dx \leq F_\infty(u, A) \leq c_2 \int_A (1 + |Du|^\alpha) \, dx$$

for every $A \in \mathcal{A}_0$ and $u \in W^{1,\alpha}(A)$. The same argument of remark 1.1 shows that (16) implies

$$c_1 |p|^\alpha \leq f_\infty(x, p) \leq c_2 (1 + |p|^\alpha)$$

and the proposition is completely proved.

1.18. PROPOSITION. - Let $A \in \mathcal{A}_0$ and (F_n) be a sequence in \mathcal{F} . Let X be a subset of $W^{1,\alpha}(A)$, $\varphi: A \times \mathbf{R} \rightarrow \mathbf{R}$ be a function such that $\varphi(x, y)$ is Lebesgue measurable in x , continuous in y . Define the functionals $\Psi_n: L^\alpha(A) \rightarrow \overline{\mathbf{R}}$ by

$$\Psi_n(u) = F_n(u, A) + \int_A \varphi(x, u(x)) \, dx .$$

Suppose that

- (i) $(F_n) \Gamma(L^{\alpha'})$ converges to a functional $F_\infty \in \mathcal{F}$;
- (ii) X is weakly closed in $W^{1,\alpha}(A)$ and $X + W_0^{1,\alpha} = X$ in the sense that $u \in X$, $v \in W_0^{1,\alpha}(A)$ implies $u + v \in X$;
- (iii) $\lambda_1|y|^\alpha + \mu_1(x) \leq \varphi(x, y) \leq \lambda_2|y|^\alpha + \mu_2(x) \, \forall (x, y) \in A \times \mathbf{R}$
for some $\lambda_1 > 0, \lambda_2 > 0, \mu_1, \mu_2 \in L^1(A)$.

Then, we have that

$$\lim_{n \rightarrow +\infty} \left[\min_{u \in X} \Psi_n(u) \right] = \min_{u \in X} \Psi_\infty(u)$$

where

$$\Psi_\infty(u) = F_\infty(u, A) + \int_A \varphi(x, u(x)) \, dx .$$

Moreover, any sequence (u_n) in X such that

$$\Psi_n(u_n) = \min_{u \in X} \Psi_n(u)$$

does contain a subsequence that converges in $L_{loc}^\alpha(A)$, weakly in $W^{1,\alpha}(A)$, and pointwise almost everywhere in A to a function $u_\infty \in X$ such that

$$\Psi_\infty(u_\infty) = \min_{u \in X} \Psi_\infty(u) .$$

If, in addition, A has Lipschitz continuous boundary, then the convergence of the subsequence of (u_n) takes place also in $L^\alpha(A)$. Finally, if $X = u_0 + W_0^{1,\alpha}(A)$ with $u_0 \in W^{1,\alpha}(A)$, then the left-hand side of (iii) may be relaxed by requiring only $\lambda_1 > -c_1|P_A$ and again the convergence of the subsequence of (u_n) takes place also in $L^\alpha(A)$.

PROOF. - By proposition 1.7, all the functionals Ψ_n and Ψ_∞ attain their minimum in X . Let (u_n) be a sequence in X such that

$$\Psi_n(u_n) = \min_{u \in X} \Psi_n(u) .$$

As in the proof of 1.7, (u_h) is bounded in $W^{1,\alpha}(A)$, so corollary 1.4 gives that there exists a subsequence $(u_{\sigma(h)})$ that converges in $L^{\alpha}_{loc}(A)$, weakly in $W^{1,\alpha}(A)$ and pointwise almost everywhere to a function u_{∞} and such that

$$(17) \quad \liminf_{h \rightarrow +\infty} \left(\min_{u \in X} \Psi_h(u) \right) = \liminf_{h \rightarrow +\infty} \left(\min_{u \in X} \Psi_{\sigma(h)}(u) \right).$$

This convergence takes place also in $L^{\alpha}(A)$ if ∂A is Lipschitz continuous or $X = u_0 + W^{1,\alpha}_0(A)$. We want to prove that u_{∞} is a minimum point of Ψ_{∞} in X . Since X is weakly closed, $u_{\infty} \in X$.

Now, let us endow X with the metric induced by $L^{\alpha}(A)$ and suppose we have proved that

$$(18) \quad \Psi_{\infty}(u_{\infty}) \leq \liminf_{h \rightarrow +\infty} \Psi_{\sigma(h)}(u_{\sigma(h)})$$

$$(18') \quad \Gamma(X^-) \lim_{h \rightarrow +\infty} \Psi_h(u) = \Psi_{\infty}(u), \quad \forall u \in X.$$

Then, by (18)

$$\Psi_{\infty}(u_{\infty}) \leq \liminf_{h \rightarrow +\infty} \Psi_{\sigma(h)}(u_{\sigma(h)}) = \liminf_{h \rightarrow +\infty} \left[\min_{u \in X} \Psi_{\sigma(h)}(u) \right] = \liminf_{h \rightarrow +\infty} \left[\min_{u \in X} \Psi_h(u) \right].$$

On the other hand, applying definition (13) of $\Gamma(X^-)$ convergence and (18'), for any $v \in X$ there exists a sequence (v_h) in X such that

$$\Psi_{\infty}(v) \geq \limsup_{h \rightarrow +\infty} \Psi_h(v_h) \geq \limsup_{h \rightarrow +\infty} \left[\min_{u \in X} \Psi_h(u) \right].$$

We conclude that $\Psi_{\infty}(v) \geq \Psi_{\infty}(u_{\infty})$ for any $v \in X$, hence u_{∞} is a minimum point of Ψ_{∞} in X , and also, by taking $v = u_{\infty}$, that

$$\Psi_{\infty}(u_{\infty}) \leq \liminf_{h \rightarrow +\infty} \left[\min_{u \in X} \Psi_h(u) \right] \leq \limsup_{h \rightarrow +\infty} \left[\min_{u \in X} \Psi_h(u) \right] \leq \Psi_{\infty}(u_{\infty})$$

so our proposition is proved. It remains to check (18) and (18').

Let us prove (18). Fix $B \in \mathcal{A}_0$ with $B \subset\subset A$; the sequence $(u_{\sigma(h)})$ converges in $L^{\alpha}(B)$ to u_{∞} and the sequence $((F_{\sigma(h)})_B) \Gamma(L^{\alpha}(B)^-)$ converges to $(F_{\infty})_B$ (see proposition 1.15 (b)), hence by the definition (12) of Γ -convergence we obtain that

$$F_{\infty}(u_{\infty}, B) \leq \liminf_{h \rightarrow +\infty} F_{\sigma(h)}(u_{\sigma(h)}, B) \leq \liminf_{h \rightarrow +\infty} F_{\sigma(h)}(u_{\sigma(h)}, A).$$

On the other hand, if $\lambda_1 \geq 0$, Fatou's lemma (recall that $(u_{\sigma(h)})$ converges pointwise almost everywhere to u_{∞}) yields

$$\liminf_{h \rightarrow +\infty} \int_A \varphi(x, u_{\sigma(h)}(x)) \, dx \geq \int_A \varphi(x, u_{\infty}(x)) \, dx.$$

The same result may be obtained in the case $X = u_0 + W_0^{1,\alpha}(A)$, even if $\lambda_1 < 0$, applying Fatou's lemma to $\varphi(x, u_{\sigma(h)}(x)) - \lambda_1 |u_{\sigma(h)}(x)|^\alpha$ and recalling that in this case $(u_{\sigma(h)})$ converges to u_∞ in $L^\alpha(A)$.

So we conclude that

$$F_\infty(u_\infty, B) + \int_A \varphi(x, u_\infty(x)) \, dx \leq \liminf_{h \rightarrow +\infty} \left[F_{\sigma(h)}(u_{\sigma(h)}, A) + \int_A \varphi(x, u_{\sigma(h)}(x)) \, dx \right] = \liminf_{h \rightarrow +\infty} \Psi_{\sigma(h)}(u_{\sigma(h)}).$$

By taking $B \uparrow A$ (prop. 1.2), (18) is proved.

Let us prove (18'). If we denote

$$\Phi(u) = \int_A \varphi(x, u(x)) \, dx \quad (u \in L^\alpha(A))$$

and remark that by (iii)

$$|\varphi(x, y)| \leq (|\lambda_1| + \lambda_2) |y|^\alpha + |\mu_1(x)| + |\mu_2(x)|, \quad \forall (x, y) \in A \times \mathbf{R}$$

then the basic continuity result of Nemitski's operators (e.g. see [23], th. 19.1, pg. 154) gives that Φ is continuous in $L^\alpha(A)$, hence in X .

Recalling definition (12), (13) of $\Gamma(X^-)$ convergence, the $\Gamma(X^-)$ convergence of $(\Psi_h) = ((F_h)_A + \Phi)$ to $\Psi_\infty = (F_\infty)_A + \Phi$ is equivalent to the $\Gamma(X^-)$ convergence of $((F_h)_A)$ to $(F_\infty)_A$, hence we have only to prove that

$$\Gamma(X^-) \lim_{h \rightarrow +\infty} (F_h)_A(u) = (F_\infty)_A(u), \quad \forall u \in X.$$

The property (12) is trivial because X is a topological subspace of $L^\alpha(A)$ and hypothesis (i) holds. Let us verify (13'), by taking $v_\infty \in X$ and by proving that for every $\varepsilon > 0$ there exists a sequence (v_h) in X converging to v_∞ such that

$$(19) \quad \limsup_{h \rightarrow +\infty} F_h(v_h, A) \leq (1 + \varepsilon) F_\infty(v_\infty, A) + C\varepsilon$$

where $C = C(v_\infty)$ is a real constant depending only on v_∞ . Let us fix $\varepsilon \in]0, 1[$. Hypothesis (i) gives a sequence (w_h) converging in $L^\alpha(A)$ to v_∞ such that

$$F_\infty(v_\infty, A) \geq \limsup_{h \rightarrow +\infty} F_h(w_h, A).$$

We want to obtain $v_h \in X$ by modifying in a suitable way w_h . Let us choose a compact subset K of A such that

$$\int_{A \setminus K} (1 + |Dv_\infty|^\alpha) \, dx < \varepsilon$$

(recall that $v_\infty \in X \subseteq W^{1,\alpha}(A)$) and moreover $A_1, A_2 \in \mathcal{A}_0$ such that $K \subseteq A_1 \subset\subset A_2 \subset\subset A$. Applying theorem 6.1 of [5], we construct $M > 0$ and finite number $\varphi_1, \dots, \varphi_k$ of function of $C_0^\infty(A_2)$ such that $0 \leq \varphi_i \leq 1$ and $\varphi_i = 1$ on A_1 ($i = 1, 2, \dots, k$) and

$$\min_{1 \leq i \leq k} F_h(\varphi_i w_h + (1 - \varphi_i)v_\infty, A) \leq (1 + \varepsilon)[F_h(w_h, A) + F_h(v_\infty, A \setminus K)] + \varepsilon[\|w_h\|_{L^\alpha(A)}^\alpha + \|v_\infty\|_{L^\alpha(A \setminus K)}^\alpha + 1] + M\|w_h - v_\infty\|_{L^\alpha(A \setminus K)}$$

for every $h \in \mathbf{N}$. Denote by i_h the index i for which the previous minimum is attained and let $v_h = \varphi_{i_h} w_h + (1 - \varphi_{i_h})v_\infty$. Then $v_h = v_\infty + \varphi_{i_h}(w_h - v_\infty) \in X$. Moreover

$$\|v_h - v_\infty\|_{L^\alpha(A)} \leq \|w_h - v_\infty\|_{L^\alpha(A)}, \quad \forall h \in \mathbf{N}$$

hence (v_h) converges in X to v_∞ . Finally, by using the previous inequalities and equiboundedness (5), we obtain that

$$\limsup_{h \rightarrow +\infty} F_h(v_h, A) \leq (1 + \varepsilon) \left[\limsup_{h \rightarrow +\infty} F_h(w_h, A) + c_2 \int_{A \setminus K} (1 + |Dv_\infty|^\alpha) dx \right] + \varepsilon[2\|v_\infty\|_{L^\alpha(A)} + 1] \leq (1 + \varepsilon)F_\infty(v_\infty, A) + \varepsilon[2c_2 + 2\|v_\infty\|_{L^\alpha(A)} + 1]$$

so (19) and our proposition are proved.

1.19. COROLLARY. - *In addition to the hypotheses of proposition 1.18, suppose that Ψ_∞ has a unique minimum point in X (for example, if X is convex and Ψ_∞ is strictly convex on X). Then any sequence (u_h) of minimizers converges in $L_{loc}^\alpha(A)$ and weakly in $W^{1,\alpha}(A)$ to the minimum point of Ψ_∞ in X . If A has a Lipschitz continuous boundary or $X = u_0 + W_0^{1,\alpha}(A)$ with $u_0 \in W^{1,\alpha}(A)$, then the convergence takes place also in $L^\alpha(A)$.*

PROOF. - Let u_∞ be the minimum point of Ψ_∞ in X and suppose that (u_h) does not converge to u_∞ in $L_{loc}^\alpha(A)$ (resp. weakly in $W^{1,\alpha}(A)$). Then there exists a subsequence $(u_{\sigma(h)})$ such that no further subsequence converges to u_∞ in $L_{loc}^\alpha(A)$ (resp. weakly in $W^{1,\alpha}(A)$), but this contradicts proposition 1.18 applied to $\Psi_{\sigma(h)}$ (recall proposition 1.15 (b)).

1.20. EXAMPLE. - The most known example of application of the previous propositions is given by the sequences of quadratic forms

$$F_h(u, A) = \int_A \sum_{i,j=1}^n a_{ij}^{(h)}(x) D_i u D_j u dx \quad (u \in W^{1,2}(A))$$

where

$$c_1|p|^2 \leq \sum_{i,j=1}^n a_{ij}^{(h)}(x) p_i p_j \leq c_2|p|^2, \quad \forall (x, p) \in \mathbf{R}^n$$

and $a_{ij}^{(h)} = a_{ij}^{(h)}$ are Lebesgue measurable functions, for every $h \in \mathbf{N}$, $i, j = 1, \dots, n$. By taking $X = u_0 + W_0^{1,2}(A)$ and $\varphi(x, y) = 2y\chi(x)$ with $u_0 \in W^{1,2}(A)$ and $\chi \in L^2(A)$ (recall remark 1.8), proposition 1.18 and corollary 1.19 give that the $\Gamma(L^2)$ convergence of (F_h) to F_∞ implies the convergence in $L^2(A)$ of the solutions (u_h) of the Dirichlet problems

$$\sum_{i,j=1}^n D_i(a_{ij}^{(h)} D_j u_h) = \chi \quad \text{on } A, \quad u_h = u_0 \quad \text{on } \partial A$$

to the solution u_∞ of the corresponding problem for F_∞ : in fact it may be proved that F_∞ also is a quadratic form with eigenvalues in $[c_1, c_2]$. In particular, the operators $\left(\sum_{i,j=1}^n D_i(a_{ij}^{(h)} D_j)\right)$ G -converge in the sense of S. SPAGNOLO [21] to the corresponding limit operator $\sum_{i,j=1}^n D_i(a_{ij}^{(\infty)} D_j)$. Even the converse is true: G -convergence of the Euler operators implies Γ -convergence of the energies (see [8]). The case $a_{ij}^{(h)}(x) = a_{ij}(hx)$, with a_{ij} periodic, is the case of the classical homogenization.

1.21. PROPOSITION. - *Let (F_h) be a sequence in \mathcal{F} and $F_\infty \in \mathcal{F}$. Then the following conditions are equivalent:*

- (i) $\lim_{h \rightarrow +\infty} d(F_h, F_\infty) = 0$;
- (ii) $\Gamma(L^{\alpha-}) \lim_{h \rightarrow +\infty} F_h = F_\infty$;
- (iii) $\lim_{h \rightarrow +\infty} (T_\varepsilon F_h)(u, A) = (T_\varepsilon F_\infty)(u, A), \quad \forall \varepsilon > 0, u \in L_{loc}^\alpha(\mathbf{R}^n), A \in \mathcal{A}_0$.

PROOF. - (i) \Rightarrow (ii). Let \mathcal{W} and \mathcal{B} be the dense families employed in the definition (11) of the distance d and let $w \in \mathcal{W}$ and $B \in \mathcal{B}$. Then

$$\lim_{h \rightarrow +\infty} T_{1/i} F_h(w, B) = T_{1/i} F_\infty(w, B), \quad \forall i \in \mathbf{N}$$

and, for any sequence (u_h) converging to w in $L^\alpha(B)$,

$$T_{1/i} F_h(w, B) \leq F_h(u_h, B) + i \int_B |u_h - w|^\alpha dx, \quad \forall i, h \in \mathbf{N}$$

so, recalling proposition 1.11,

$$(20) \quad F_\infty(w, B) = \lim_{i \rightarrow +\infty} \lim_{h \rightarrow +\infty} T_{1/i} F_h(w, B) \leq \liminf_{i \rightarrow +\infty} \liminf_{h \rightarrow +\infty} \left[F_h(u_h, B) + i \int_B |u_h - w|^\alpha dx \right] = \liminf_{h \rightarrow +\infty} F_h(u_h, B).$$

Moreover, if $u_{i,h} \in W^{1,\alpha}(B)$ denotes the function such that

$$T_{1/i}F_h(w, B) = F_h(u_{i,h}, B) + i \int_B |u_{i,h} - w|^\alpha dx$$

(recall (10')), we may estimate

$$\begin{aligned} \|u_{i,h} - w\|_{L^\alpha(B)}^\alpha &\leq \frac{1}{i} [T_{1/i}F_h(w, B) - F_h(u_{i,h}, B)] \leq \frac{1}{i} T_{1/i}F_h(w, B) \leq \\ &\leq \frac{1}{i} F_h(w, B) \leq \frac{c_2}{i} \int_B (1 + |Dw|^\alpha) dx. \end{aligned}$$

It follows that, if U_r is the ball of $L^\alpha(B)$ with center w and radius r , then for i large enough (independently of h) we have $u_{i,h} \in U_r$, hence

$$T_{1/i}F_h(w, B) = \min_{u \in W^{1,\alpha}(B)} \left[F_h(u, B) + i \int_B |u - w|^\alpha dx \right] = \inf_{u \in U_r} \left[F_h(u, B) + i \int_B |u - w|^\alpha dx \right]$$

and we conclude that

$$\begin{aligned} (21) \quad F_\infty(w, B) &\geq T_{1/i}F_\infty(w, B) = \lim_{h \rightarrow +\infty} T_{1/i}F_h(w_1, B) = \\ &= \lim_{h \rightarrow +\infty} \inf_{u \in U_r} \left[F_h(u, B) + i \int_B |u - w|^\alpha dx \right] \geq \limsup_{h \rightarrow +\infty} \inf_{u \in U_r} F_h(u, B). \end{aligned}$$

Recalling the definition (12), (13') of Γ -convergence, (20) and (21) say that

$$\Gamma(L^\alpha(B)^-) \lim_{h \rightarrow +\infty} (F_h)_B(w) = (F_\infty)_B(w), \quad \forall w \in \mathcal{W}, B \in \mathcal{B}.$$

On the other hand, for any subsequence $(F_{\sigma(h)})$ there exists a sub-subsequence $(F_{\sigma(\tau(h))})$ that $\Gamma(L^{\alpha^-})$ converges (compactness theorem 1.17): its limit G_∞ depends a priori on τ and σ but, observing that by proposition 1.15 (b) we have

$$(G_\infty)_B(w) = \Gamma(L^\alpha(B)^-) \lim_{h \rightarrow +\infty} (F_{\sigma(\tau(h))})_B(w) = (F_\infty)_B(w), \quad \forall w \in \mathcal{W}, B \in \mathcal{B},$$

we conclude by corollary 1.6 that $F_\infty = G_\infty$. Since G_∞ does not depend on τ and σ , proposition 1.15 (c) applies and we obtain that

$$\Gamma(L^\alpha(A)^-) \lim_{h \rightarrow +\infty} (F_h)_A = (G_\infty)_A = (F_\infty)_A, \quad \forall A \in \mathcal{A}_0$$

so (ii) is proved.

(ii) \Rightarrow (iii) It suffices to apply proposition 1.18 with $X = W^{1,\alpha}(A)$ and $\varphi(x, y) = (1/\varepsilon)|u(x) - y|^\alpha$.

(iii) \Rightarrow (i) It is obvious.

1.22. COROLLARY. – *The metric space (\mathcal{F}, d) is compact, hence complete and separable.*

PROOF. – It follows from propositions 1.17 and 1.21.

1.23. COROLLARY. – *Let $A \in \mathcal{A}_0$, $X \subseteq W^{1,\alpha}(A)$, $\varphi: A \times \mathbf{R} \rightarrow \mathbf{R}$ be satisfying the hypotheses of proposition 1.18. Consider the function $\mathcal{M}_{A,X,\varphi}: \mathcal{F} \rightarrow \mathbf{R}$ defined by*

$$\mathcal{M}_{A,X,\varphi}(F) = \min_{u \in X} \left[F(u, A) + \int_A \varphi(x, u(x)) \, dx \right]$$

and the multivalued map $\mathcal{M}'_{A,X,\varphi}: \mathcal{F} \rightarrow W^{1,\alpha}(A)$ defined by

$$\mathcal{M}'_{A,X,\varphi}(F) = \left\{ u \in X: F(u, A) + \int_A \varphi(x, u(x)) \, dx = \mathcal{M}_{A,X,\varphi}(F) \right\}.$$

Then $\mathcal{M}_{A,X,\varphi}$ is continuous on (\mathcal{F}, d) and $\mathcal{M}'_{A,X,\varphi}$ is upper semi-continuous on (\mathcal{F}, d) , in the sense that, if (F_h) is a sequence converging in \mathcal{F} to F_∞ and (u_h) is a sequence in X converging to u_∞ weakly in $W^{1,\alpha}(A)$ (resp. $L^\alpha_{\text{loc}}(A)$) such that $u_h \in \mathcal{M}'_{A,X,\varphi}(F_h)$, then $u_\infty \in \mathcal{M}'_{A,X,\varphi}(F_\infty)$.

Finally, if \mathcal{G} is a closed subset of \mathcal{F} such that $\mathcal{M}'_{A,X,\varphi}(G)$ is formed by a single point for every $G \in \mathcal{G}$, then $\mathcal{M}'_{A,X,\varphi}$ is continuous on \mathcal{G} as single-valued map with values in $W^{1,\alpha}(A)$ with its weak topology or in $L^\alpha_{\text{loc}}(A)$. If, in addition, A has Lipschitz continuous boundary or $X = u_0 + W^{1,\alpha}_0(A)$, then $L^\alpha_{\text{loc}}(A)$ may be replaced by $L^\alpha(A)$.

PROOF. – It suffices to apply propositions 1.18 and 1.21 and, for the last part of the statement, corollary 1.19.

1.24. REMARK. – An example of \mathcal{G} to which one may apply the previous result is the set of the quadratic forms of example 1.20.

1.25. COROLLARY. – *Let $u \in L^\alpha_{\text{loc}}(\mathbf{R}^n)$ and $A \in \mathcal{A}_0$ be fixed. Then, for every $\varepsilon > 0$ the function $F \rightarrow (T_\varepsilon F)(u, A)$ defined on \mathcal{F} with values in $\overline{\mathbf{R}}$ is continuous on (\mathcal{F}, d) . If, in addition, $u|_A \in W^{1,\alpha}(A)$ then these functions are bounded independently of ε .*

PROOF. – Continuity is a consequence of corollary 1.23 when $X = W^{1,\alpha}(A)$ and $\varphi(x, y) = (1/\varepsilon)|u(x) - y|^\alpha$. Equiboundedness is given by

$$0 \leq T_\varepsilon F(u, A) \leq F(u, A) \leq c_2 \int_A (1 + |Du|^\alpha) \, dx, \quad \forall \varepsilon > 0, \forall F \in \mathcal{F}.$$

Since \mathcal{F} is a set of real extended functions on the set $T = L^\alpha_{\text{loc}}(\mathbf{R}^n) \times \mathcal{A}_0$, we might consider on \mathcal{F} the product σ -field induced by $\overline{\mathbf{R}}^T$ where $\overline{\mathbf{R}}$ is endowed with the Borel σ -field. Moreover we might consider the Borel σ -field induced on \mathcal{F} by the metric d .

1.26. THEOREM. - *The Borel σ -field \mathfrak{G}_B on (\mathcal{F}, d) coincides with the trace on \mathcal{F} of the product σ -field of $\overline{\mathbf{R}}^x$, where $T = L_{loc}^\alpha(\mathbf{R}^n) \times \mathcal{A}_0$ and $\overline{\mathbf{R}}$ is endowed with the Borel σ -field. Equivalently, \mathfrak{G}_B is the intersection of all the σ -fields \mathfrak{G} on \mathcal{F} such that, for every $u \in L_{loc}^\alpha(\mathbf{R}^n)$ and $A \in \mathcal{A}_0$, the evaluation map $F \rightarrow F(u, A)$ defined on \mathcal{F} with values in $\overline{\mathbf{R}}$ is measurable as function between $(\mathcal{F}, \mathfrak{G})$ and the Borel line.*

PROOF. - Fix $u \in L_{loc}^\alpha(\mathbf{R}^n)$ and $A \in \mathcal{A}_0$. The evaluation map $F \rightarrow F(u, A)$ is lower semicontinuous on (\mathcal{F}, d) because, if (F_n) is a sequence converging to F_∞ in \mathcal{F} , then proposition 1.21 and (12) applied with $u_n = u$ give that

$$F(u, A) \leq \liminf_{n \rightarrow +\infty} F_n(u, A).$$

It follows that \mathfrak{G}_B belongs to the family of the σ -fields such that any evaluation map is measurable. Now, we want to prove that \mathfrak{G}_B is the smallest of such σ -fields. Let \mathfrak{G} be one of these σ -fields. If (w_j^A) is a sequence dense in $W^{1,\alpha}(A)$, then

$$(T_\varepsilon F)(u, A) = \inf_{j \in \mathbf{N}} \left\{ F(w_j^A, A) + \frac{1}{\varepsilon} \int_A |u - w_j^A|^\alpha dx \right\}, \quad \forall \varepsilon > 0, \forall u \in L_{loc}^\alpha(\mathbf{R}^n), \forall A \in \mathcal{A}_0$$

by (10') and proposition 1.5, hence the map $F \rightarrow (T_\varepsilon F)(u, A)$ is \mathfrak{G} -measurable, being the infimum of countably many \mathfrak{G} -measurable functions, for every $\varepsilon > 0$, $u \in L_{loc}^\alpha(\mathbf{R}^n)$ and $A \in \mathcal{A}_0$. By the definition (11) of the distance d , we obtain that even the function $F \rightarrow d(F, F_0)$ is measurable for every $F_0 \in \mathcal{F}$, therefore all the balls in \mathcal{F} belong to \mathfrak{G} . Finally, as \mathcal{F} is a metric separable space (corollary 1.22), each open subset of (\mathcal{F}, d) is the union of a countable family of open balls, hence $\mathfrak{G} \supseteq \mathfrak{G}_B$ and the theorem is proved.

2. - Random integral functionals.

From now on, $(\Omega, \mathfrak{G}, P)$ will denote a probability space, that is Ω is a set, \mathfrak{G} is a σ -field of subsets of Ω and P is a probability measure on \mathfrak{G} .

A random integral functional is any measurable function $F: \Omega \rightarrow \mathcal{F}$ when Ω is endowed with the σ -field \mathfrak{G} and \mathcal{F} with the Borel σ -field \mathfrak{G}_B generated by the distance d (see section 1).

2.1. PROPOSITION. - *Let $F: \Omega \rightarrow \mathcal{F}$ be a function. F is a random integral functional if and only if, for every $u \in L_{loc}^\alpha(\mathbf{R}^n)$ and $A \in \mathcal{A}_0$, the function $\omega \rightarrow [F(\omega)](u, A)$ is a (real extended) random variable, i.e. it is measurable as function between (Ω, \mathfrak{G}) and the Borel line.*

PROOF. - It is a direct consequence of theorem 1.26 and of the fact that a function F from a measurable space (Ω, \mathfrak{G}) into the product $\overline{\mathbf{R}}^x$ of Borel lines is meas-

urable if and only if the functions $\pi_t \circ F$ are measurable for every $t \in T$, where π_t is the projection of $\bar{\mathbf{R}}^x$ on its factor with index t (e.g. see [15], sec. 5).

2.2. COROLLARY. - *Let F be a random integral functional, $u \in L_{loc}^\alpha(\mathbf{R}^n)$, $A \in \mathcal{A}_0$. Then, for every $\varepsilon > 0$ and for every $X \subseteq W^{1,\alpha}(A)$ and $\varphi: A \times \mathbf{R} \rightarrow \mathbf{R}$ satisfying the hypotheses of proposition 1.18, the functions $\omega \rightarrow [T_\varepsilon(F(\omega))](u, A)$ and $\omega \rightarrow \mathcal{M}_{A, X, \varphi}(F(\omega))$ (see corollary 1.23) between Ω and $\bar{\mathbf{R}}$ are real extended random variables.*

PROOF. - It follows from corollaries 1.25 and 1.23.

If F is a random integral functional, the image measure $F_\# P$ on \mathcal{F} , defined by $(F_\# P)(S) = P(F^{-1}(S))$ for every $S \in \mathcal{G}_B$, is called the distribution law of F . We shall write $F \sim G$ if F and G are random integral functionals having the same distribution law.

2.3. PROPOSITION. - *Let F, G be two random integral functionals. We have $F \sim G$ if and only if, whenever u_1, \dots, u_N are a finite number of functions of $L_{loc}^\alpha(\mathbf{R}^n)$ and A_1, \dots, A_N are a finite number of open sets of \mathcal{A}_0 , the distribution laws of the two vector random variables*

$$\begin{aligned} \omega &\rightarrow (F(\omega)(u_1, A_1), \dots, F(\omega)(u_N, A_N)) \\ \omega &\rightarrow (G(\omega)(u_1, A_1), \dots, G(\omega)(u_N, A_N)) \end{aligned}$$

are equal.

PROOF. - It is again a direct consequence of theorem 1.26 and of the fact that two probability measures μ and ν on a product space $\bar{\mathbf{R}}^x$ agree if and only if $\pi_{\#} \mu = \pi_{\#} \nu$ for every projection π_f on a finite number of factors of $\bar{\mathbf{R}}^x$ (e.g. see [15], sec. 4).

For every $c \in \mathbf{R}^n$ and $\varepsilon > 0$ we want to define the operators τ_c and ϱ_ε respectively of translation and of homothety. If $u \in L_{loc}^\alpha(\mathbf{R}^n)$, then $\tau_c u \in L_{loc}^\alpha(\mathbf{R}^n)$ is defined by $(\tau_c u)(x) = u(x - c)$ while $\varrho_\varepsilon u \in L_{loc}^\alpha(\mathbf{R}^n)$ is defined by $(\varrho_\varepsilon u)(x) = (1/\varepsilon)u(\varepsilon x)$. If $A \in \mathcal{A}_0$, then $\tau_c A = \{x \in \mathbf{R}^n: x - c \in A\}$ and $\varrho_\varepsilon A = \{x \in \mathbf{R}^n: \varepsilon x \in A\}$. Finally, if $F \in \mathcal{F}$, then the functionals $\tau_c F \in \mathcal{F}$, $\varrho_\varepsilon F \in \mathcal{F}$ are defined by

$$(22) \quad (\tau_c F)(u, A) = F(\tau_c u, \tau_c A), \quad (\varrho_\varepsilon F)(u, A) = \varepsilon^n F(\varrho_\varepsilon u, \varrho_\varepsilon A)$$

for every $u \in L_{loc}^\alpha(\mathbf{R}^n)$ and $A \in \mathcal{A}_0$.

If $f(x, p)$ denotes the integrand of a functional $F \in \mathcal{F}$ (recall remark 1.1) then it is very easy to check that

$$\begin{aligned} \tau_c F(u, A) &= \int_A f(x + c, Du(x)) \, dx \\ \varrho_\varepsilon F(u, A) &= \int_A f\left(\frac{x}{\varepsilon}, Du(x)\right) \, dx \end{aligned}$$

for every $u \in W_{loc}^\alpha(\mathbf{R}^n)$ and $A \in \mathcal{A}_0$.

2.4. COROLLARY. - Let $c \in \mathbf{R}^n$, $\varepsilon > 0$ and F be a random integral functional. Then the functions $\tau_\varepsilon F$, $\varrho_\varepsilon F: \Omega \rightarrow \mathcal{F}$ defined by

$$(\tau^\varepsilon F)(\omega) = \tau_c(F(\omega)), \quad (\varrho_\varepsilon F)(\omega) = \varrho_c(F(\omega)), \quad \forall \omega \in \Omega$$

are random integral functionals. Moreover, if G is another random integral functional such that $F \sim G$, then we have also $\tau_\varepsilon F \sim \tau_\varepsilon G$ and $\varrho_\varepsilon F \sim \varrho_\varepsilon G$.

PROOF. - It suffices to apply propositions 2.1 and 2.3 and (22).

Let X, Y be two real or real extended random variables defined on Ω and suppose $X, Y \in L^2(\Omega, P)$. Then the covariance of X and Y is defined by

$$\text{cov}(X, Y) = \int_{\Omega} (X(\omega) - E[X])(Y(\omega) - E[Y]) dP(\omega),$$

where

$$E[X] = \int_{\Omega} X(\omega) dP(\omega), \quad E[Y] = \int_{\Omega} Y(\omega) dP(\omega).$$

If $\text{cov}(X, Y) = 0$ we say that X and Y are uncorrelated. If X and Y are independent, then $\text{cov}(X, Y) = 0$ (see [15], sec. 15). Finally, the variance of X is defined by $\sigma^2(X) = \text{cov}(X, X)$.

2.5. THEOREM. - Let (F_h) be a sequence of random integral functionals with F_h defined on the probability space $(\Omega_h, \mathcal{F}_h, P_h)$. Let F_∞ be a random integral functional defined on $(\Omega_\infty, \mathcal{F}_\infty, P_\infty)$. Suppose that (F_h) converges in law to F_∞ , in the sense that the corresponding laws $\mu_h = F_{h\#} P_h$ converge weakly* as $h \rightarrow +\infty$ to $\mu_\infty = F_{\infty\#} P_\infty$, i.e.

$$\lim_{h \rightarrow +\infty} \int_{\mathcal{F}} \Psi(F) d\mu_h(F) = \int_{\mathcal{F}} \Psi(F) d\mu_\infty(F)$$

for every continuous function $\Psi: \mathcal{F} \rightarrow \mathbf{R}$. Then, whenever $u, v \in L^{\alpha}_{\text{loc}}(\mathbf{R}^n)$ and $A, B \in \mathcal{A}_0$ are such that $u|_A \in W^{1,\alpha}(A)$ and $v|_B \in W^{1,\alpha}(B)$, we have

$$\lim_{\varepsilon \rightarrow 0^+} \lim_{h \rightarrow +\infty} \text{cov}([T_\varepsilon F_h(\cdot)](u, A), [T_\varepsilon F_h(\cdot)](v, B)) = \text{cov}([F_\infty(\cdot)](u, A), [F_\infty(\cdot)](v, B)).$$

PROOF. - Fix $u, v \in L^{\alpha}_{\text{loc}}(\mathbf{R}^n)$, $A, B \in \mathcal{A}_0$ such that $u|_A \in W^{1,\alpha}(A)$ and $v|_B \in W^{1,\alpha}(B)$. For every $\varepsilon > 0$, denote by $\Psi_1^{(\varepsilon)}$ and $\Psi_2^{(\varepsilon)}$ the functions on \mathcal{F} with values in \mathbf{R} defined by $\Psi_1^{(\varepsilon)}(F) = T_\varepsilon F(u, A)$, $\Psi_2^{(\varepsilon)}(F) = T_\varepsilon F(v, B)$. Analogously, define $\Psi_1(F) = F(u, A)$ and $\Psi_2(F) = F(v, B)$. The functions $\Psi_1^{(\varepsilon)}$ and $\Psi_2^{(\varepsilon)}$ are bounded independently of ε (corollary 1.25) and converge pointwise as $\varepsilon \rightarrow 0^+$ respectively to Ψ_1 and Ψ_2 (proposition 1.11), hence by Lebesgue's dominated convergence theorem we obtain that

$$\lim_{\varepsilon \rightarrow 0^+} \text{cov}(\Psi_1^{(\varepsilon)} \circ F_\infty, \Psi_2^{(\varepsilon)} \circ F_\infty) = \text{cov}(\Psi_1 \circ F_\infty, \Psi_2 \circ F_\infty).$$

Now, again by corollary 1.25, $\Psi_1^{(\varepsilon)}$ and $\Psi_2^{(\varepsilon)}$ are continuous and finite, so we have

$$\begin{aligned} \lim_{h \rightarrow +\infty} E[\Psi_i^{(\varepsilon)} \circ F_h] &= \lim_{h \rightarrow +\infty} \int_{\Omega_h} \Psi_i^{(\varepsilon)}(F_h(\omega)) dP_h(\omega) = \lim_{h \rightarrow +\infty} \int_{\mathcal{F}} \Psi_i^{(\varepsilon)}(F) d\mu_h(F) = \\ &= \int_{\mathcal{F}} \Psi_i^{(\varepsilon)}(F) d\mu_\infty(F) = \int_{\Omega_\infty} \Psi_i^{(\varepsilon)}(F_\infty(\omega)) dP_\infty(\omega) = E[\Psi_i^{(\varepsilon)} \circ F_\infty] \end{aligned}$$

for $i = 1, 2$. By the same argument, we obtain also

$$\lim_{h \rightarrow +\infty} \int_{\Omega_h} \Psi_1^{(\varepsilon)}(F_h(\omega)) \Psi_2^{(\varepsilon)}(F_h(\omega)) dP_h(\omega) = \int_{\Omega_\infty} \Psi_1^{(\varepsilon)}(F_\infty(\omega)) \Psi_2^{(\varepsilon)}(F_\infty(\omega)) dP_\infty(\omega)$$

so we conclude that

$$\lim_{h \rightarrow +\infty} \text{cov}(\Psi_1^{(\varepsilon)} \circ F_h, \Psi_2^{(\varepsilon)} \circ F_h) = \text{cov}(\Psi_1^{(\varepsilon)} \circ F_\infty, \Psi_2^{(\varepsilon)} \circ F_\infty)$$

and the theorem is proved.

2.6. REMARK. - Note that in the previous theorem no general statement of the form

$$\lim_{h \rightarrow +\infty} \text{cov}(F_h(\cdot)(u, A), F_h(\cdot)(v, B)) = \text{cov}(F_\infty(\cdot)(u, A), F_\infty(\cdot)(v, B))$$

could be obtained. Indeed, the convergence in \mathcal{F} (L^2 convergence) is not comparable with pointwise convergence (see [6], pg. 118-119).

2.7. PROPOSITION. - Let F be a random integral functional. If $A, B \in \mathcal{A}_0$ and the families of random functions

$$\omega \rightarrow (F(\omega)(u, A))_{u \in L_{loc}^\alpha(\mathbf{R}^n)} \quad \text{and} \quad \omega \rightarrow (F(\omega)(u, B))_{u \in L_{loc}^\alpha(\mathbf{R}^n)}$$

are independent, then for every $\varepsilon > 0$ and $u \in L_{loc}^\alpha(\mathbf{R}^n)$ the real extended random variables $\omega \rightarrow [T_\varepsilon F(\omega)](u, A)$ and $\omega \rightarrow [T_\varepsilon F(\omega)](u, B)$ are independent (and, in particular, uncorrelated).

PROOF. - It suffices to observe that by (10') and proposition 1.5

$$T_\varepsilon F(\omega)(u, A) = \inf_{j \in \mathbf{N}} \left\{ F(\omega)(w_j^A, A) + \int_A |w_j^A - u|^\alpha dx \right\}, \quad \forall \omega \in \Omega$$

where (w_j^A) is any dense sequence in $W^{1,\alpha}(A)$, and analogously for $T_\varepsilon F(\omega)(u, B)$. Indeed, as the two sequences $(F(\cdot)(w_j^A, A))_{j \in \mathbf{N}}$, $(F(\cdot)(w_j^B, B))_{j \in \mathbf{N}}$ are independent, their infima are independent (e.g. see [15], sec. 15).

The following result will be crucial in the proof of our main theorem.

2.8. THEOREM. - Let F be a random integral functional. Suppose that the random variables $\omega \rightarrow F(\omega)(u, A)$ and $\omega \rightarrow F(\omega)(u, B)$ are uncorrelated for every $u \in W^{1,\alpha}(\mathbf{R}^n)$ and for every $A, B \in \mathcal{A}_0$ with $\bar{A} \cap \bar{B} = \emptyset$. Then there exists $F_0 \in \mathcal{F}$ such that $F(\omega) = F_0$ for P -almost all $\omega \in \Omega$.

PROOF. - Let us choose a countable dense subset \mathcal{W} of $W^{1,\alpha}(\mathbf{R}^n)$ formed by Lipschitz continuous functions and a countable dense subfamily \mathcal{B} of \mathcal{A}_0 . Suppose we have proved that

$$(23) \quad \sigma^2(F(\cdot)(w, B)) = \int_{\Omega} \left[F(\omega')(w, B) - \int_{\Omega} F(\omega)(w, B) dP(\omega) \right]^2 dP(\omega') = 0$$

for every $w \in \mathcal{W}$ and $B \in \mathcal{B}$. Then, taking into account the fact that \mathcal{W} and \mathcal{B} are countable, there exists $\Omega' \subseteq \Omega$ such that $P(\Omega') = 1$ and

$$F(\omega')(w, B) = \int_{\Omega} F(\omega)(w, B) dP(\omega), \quad \forall \omega' \in \Omega', w \in \mathcal{W}, B \in \mathcal{B}.$$

Now, if ω'_0 is any point in Ω' , define $F_0 = F(\omega'_0)$. Since

$$F_0(w, B) = F(\omega'_0)(w, B) = \int_{\Omega} F(\omega)(w, B) dP(\omega) = F(\omega')(w, B)$$

for every $\omega' \in \Omega', w \in \mathcal{W}, B \in \mathcal{B}$, corollary 1.6 yields that $F(\omega') = F_0$ for every $\omega' \in \Omega'$ and the thesis is achieved.

Let us prove (23). Fix $w \in \mathcal{W}, B \in \mathcal{B}$ and denote by L the Lipschitz constant of w . For every $C \in \mathcal{A}_0$ denote by $\Psi_C: \Omega \rightarrow \mathbf{R}$ the random variable defined by $\Psi_C(\omega) = F(\omega)(w, C)$. For every $N \in \mathbf{N}$, let us select a finite number B_1, \dots, B_N of open subsets of B so that

$$\begin{aligned} \bar{B}_i \cap \bar{B}_j &= \emptyset, & \forall i, j = 1, \dots, N, i \neq j \\ \frac{|B|}{N+1} &\leq |B_i| \leq \frac{|B|}{N}, & \forall i = 1, \dots, N \end{aligned}$$

where $|\cdot|$ denotes the Lebesgue measure in \mathbf{R}^n . Note that

$$\sigma^2\left(\sum_{i=1}^N \Psi_{B_i}\right) = \sum_{i=1}^N \sigma^2(\Psi_{B_i}) + \sum_{\substack{i,j=1 \\ i \neq j}}^N \text{cov}(\Psi_{B_i}, \Psi_{B_j})$$

hence, by hypothesis

$$\sigma^2\left(\sum_{i=1}^N \Psi_{B_i}\right) = \sum_{i=1}^N \sigma^2(\Psi_{B_i}).$$

On the other hand, by equiboundedness (5), we have that

$$\Psi_{B_i}(\omega) \leq c_2(1 + L^\alpha)|B_i| \leq c_2(1 + L^\alpha)\frac{|B|}{N}$$

therefore

$$\begin{aligned} \sigma^2(\Psi_{B_i}) &= \int_{\Omega} (\Psi_{B_i}(\omega) - E[\Psi_{B_i}])^2 dP(\omega) \leq \\ &\leq 2 \int_{\Omega} (\Psi_{B_i}^2(\omega) + (E[\Psi_{B_i}])^2) dP(\omega) \leq 2 \left(2c_2^2(1 + L^\alpha)^2 \frac{|B|^2}{N^2} \right) \end{aligned}$$

and finally

$$\sigma^2\left(\sum_{i=1}^N \Psi_{B_i}\right) \leq \sum_{i=1}^N \sigma^2(\Psi_{B_i}) \leq \frac{4c_2^2(1 + L^\alpha)^2 |B|^2}{N}.$$

Now, denote $C_N = \bigcup_{i=1}^N B_i$ and $\Psi_N = \Psi_{C_N} = \sum_{i=1}^N \Psi_{B_i}$ because the sets B_i are disjoint. Note that $C_N \subseteq B$ and $|B \setminus C_N| \leq |B|/(N + 1)$, hence, if D_N is an open neighborhood of $B \setminus C_N$ with $|D_N| \leq |B|/N$, we obtain for every $\omega \in \Omega$

$$\begin{aligned} \Psi_N(\omega) = F(\omega)(w, C_N) &\leq F(\omega)(w, B) \leq F(\omega)(w, C_N) + F(\omega)(w, D_N) \leq \\ &\leq \Psi_N(\omega) + c_2(1 + L^\alpha)|D_N| \leq \Psi_N(\omega) + c_2(1 + L^\alpha) \frac{|B|}{N}. \end{aligned}$$

Then the sequence (Ψ_N) converges uniformly, and so in $L^2(\Omega, P)$, to $F(\cdot)(w, B)$ and we may conclude that

$$\sigma^2(F(\cdot)(w, B)) = \lim_{N \rightarrow +\infty} \sigma^2(\Psi_N) \leq \lim_{N \rightarrow +\infty} \frac{4c_2^2(1 + L^\alpha)^2 |B|^2}{N} = 0$$

hence (23) and the theorem are proved.

We conclude this section with some words about the convergence of sequences of random integral functionals. We have already mentioned in theorem 2.5 the convergence in law. Since \mathcal{F} is a metric space, we have also the convergence in probability. Let (F_h) be a sequence of random integral functionals on the same probability space Ω ; we say that (F_h) converges in probability to a random integral functional F_∞ if

$$(24) \quad \lim_{h \rightarrow +\infty} P\{\omega \in \Omega : d(F_h(\omega), F_\infty(\omega)) > \eta\} = 0, \quad \forall \eta > 0$$

where d is the distance on \mathcal{F} . An analogous definition holds for the limit in probability of a family $(F_\varepsilon)_{\varepsilon > 0}$ as $\varepsilon \rightarrow 0^+$.

The following proposition is well-known.

2.9. PROPOSITION. - *Let F_∞ be a constant random integral functional, that is there exists $F_0 \in \mathcal{F}$ such that $F_\infty(\omega) = F_0$ for P -almost all $\omega \in \Omega$. Then convergence in law and convergence in probability toward F_∞ are equivalent.*

PROOF. - Suppose that (F_h) is a sequence of random functionals which converges in law to F_∞ : this implies that $((F_h \# P)(S))$ converges as $h \rightarrow +\infty$ to $(F_\infty \# P)(S)$

for every open subset S of F such that $(F_{\infty\#}P)(\partial S) = 0$. As $F_{\infty\#}P$ is the Dirac measure centered at F_{∞} , for every $\eta > 0$ we have that

$$\lim_{h \rightarrow +\infty} P\{\omega \in \Omega : d(F_h(\omega), F_{\infty}) > \eta\} = \lim_{h \rightarrow +\infty} (F_{h\#}P)(S_{\eta}) = (F_{\infty\#}P)(S_{\eta}) = 0,$$

where $S_{\eta} = \{F \in \mathcal{F} : d(F, F_{\infty}) > \eta\}$, hence (F_h) converges in probability to F_{∞} . Conversely, suppose that (F_h) converges in probability to F_{∞} and let $\Psi: \mathcal{F} \rightarrow \mathbf{R}$ be a continuous function. For every $\varepsilon > 0$ there exists $\eta > 0$ such that $d(F, F_{\infty}) \leq \eta$ implies $|\Psi(F) - \Psi(F_{\infty})| < \varepsilon$. Then

$$\begin{aligned} \left| \int_{\mathcal{F}} \Psi(F) d(F_{h\#}P)(F) - \int_{\mathcal{F}} \Psi(F) d(F_{\infty\#}P)(F) \right| &\leq \int_{\Omega} |\Psi(F_h(\omega)) - \Psi(F_{\infty})| dP(\omega) = \\ &= \int_{\{\omega \in \Omega : d(F_h(\omega), F_{\infty}) \leq \eta\}} |\Psi(F_h(\omega)) - \Psi(F_{\infty})| dP(\omega) + \int_{\{\omega \in \Omega : d(F_h(\omega), F_{\infty}) > \eta\}} |\Psi(F_h(\omega)) - \Psi(F_{\infty})| dP(\omega) \leq \\ &\leq \varepsilon + \left[\max_{F \in \mathcal{F}} |\Psi(F)| \right] P\{\omega \in \Omega : d(F_h(\omega), F_{\infty}) > \eta\}. \end{aligned}$$

By letting $h \rightarrow +\infty$ and $\varepsilon \rightarrow 0^+$, the thesis follows.

3. - Main results.

Let us begin with the definition of stochastic homogenization process and of stochastically periodic integral functional, recalling that we gave in (22) the definition of the translation operator τ_c and of the homothety operator ρ_ε .

Let $(F_\varepsilon)_{\varepsilon > 0}$ be a family of random integral functionals on the same probability space Ω (see section 2). We say that (F_ε) is a stochastic homogenization process modelled on a fixed random integral functional F on Ω if $F_\varepsilon \sim \rho_\varepsilon F$ for every $\varepsilon > 0$, that is F_ε and $\rho_\varepsilon F$ have the same distribution law.

Let F be a random integral functional. We say that F is stochastically periodic with period $T > 0$ if $F \sim \tau_z F$ for every $z \in T\mathbf{Z}^n = \{x \in \mathbf{R}^n : x/T \in \mathbf{Z}^n\}$. In the following, for the sake of simplicity, we shall suppose $T = 1$ but the results remain true for any $T > 0$.

We are mainly interested in the stochastic homogenization processes modelled on a stochastically periodic random integral functional: the main feature of these processes is that their limit points in probability are translation-invariant, as the following proposition shows.

3.1. PROPOSITION. - *Let (F_ε) be a stochastic homogenization process modelled on a stochastically periodic random integral functional F . Suppose that, for a given sequence (ε_n) of real positive numbers converging to zero, the sequence (F_{ε_n}) converges in probability (see (24)) to a random integral functional F_0 . Then $\tau_c F_0 \sim F_0$ for every $c \in \mathbf{R}^n$.*

PROOF. - Denote $G_h = F_{\varepsilon_h}$. Since any sequence converging in probability contains a subsequence which converges pointwise almost everywhere (see [15], sec. 6), it is not restrictive to assume that $(G_h(\omega))$ converges in \mathcal{F} to F_0 for every $\omega \in \Omega' \subseteq \Omega$ with $P(\Omega') = 1$. Now, fix $c \in \mathbf{R}^n$ and select a sequence (z_h) in \mathbf{Z}^n so that $(\varepsilon_h z_h)$ converges to c in \mathbf{R}^n as $h \rightarrow +\infty$. Denote $c_h = \varepsilon_h z_h$. We want to prove that $(\tau_{c_h} G_h(\omega))$ converges in \mathcal{F} to $\tau_c F_0(\omega)$ for every $\omega \in \Omega'$. Fix $\omega \in \Omega'$. Since \mathcal{F} is compact, we may assume that $(\tau_{c_h} G_h(\omega))$ converges in \mathcal{F} to a functional G_∞ and prove that $G_\infty = \tau_c F_0(\omega)$. Let $A \in \mathcal{A}_0$ and $u \in L^2(A)$: by (12) and (13) there exists a sequence (u_h) converging in $L^2(A)$ to u such that

$$G_\infty(u, A) = \lim_{h \rightarrow +\infty} (\tau_{c_h} G_h(\omega))(u_h, A).$$

If $B \in \mathcal{A}_0$ and $B \subset\subset A$, we have $\tau_c B \subset \tau_{c_h} A$ for h large enough, hence by (22)

$$(\tau_{c_h} G_h(\omega))(u_h, A) = G_h(\omega)(\tau_{c_h} u_h, \tau_{c_h} A) \geq G_h(\omega)(\tau_{c_h} u_h, \tau_c B).$$

On the other hand, it is very easy to check that $(\tau_{c_h} u_h)$ converges in $L^2(\tau_c B)$ to $\tau_c u$, so by (12) applied to $(G_h(\omega))$

$$\liminf_{h \rightarrow +\infty} G_h(\omega)(\tau_{c_h} u_h, \tau_c B) \geq F_0(\omega)(\tau_c u, \tau_c B) = \tau_c F_0(\omega)(u, B).$$

We conclude that

$$G_\infty(u, A) \geq \limsup_{h \rightarrow +\infty} G_h(\omega)(\tau_{c_h} u_h, \tau_c B) \geq \liminf_{h \rightarrow +\infty} G_h(\omega)(\tau_{c_h} u_h, \tau_c B) \geq \tau_c F_0(\omega)(u, B)$$

and, by taking $B \uparrow A$ (proposition 1.2),

$$G_\infty(u, A) \geq \tau_c F_0(\omega)(u, A).$$

The proof of the opposite inequality is analogous, so we have proved that $(\tau_{c_h} G_h(\omega))$ converges in \mathcal{F} to $\tau_c F_0(\omega)$ for every $\omega \in \Omega'$.

Finally, by the hypotheses $F_{\varepsilon_h} \sim \varrho_{\varepsilon_h} F$, $\tau_{z_h} F \sim F$ and corollary 2.4, we have that

$$\tau_{c_h} G_h = \tau_{\varepsilon_h z_h} F_{\varepsilon_h} \sim \tau_{\varepsilon_h z_h} \varrho_{\varepsilon_h} F = \varrho_{\varepsilon_h} \tau_{z_h} F \sim \varrho_{\varepsilon_h} F \sim F_{\varepsilon_h}$$

(note that $\tau_{\varepsilon_h} \varrho_{\varepsilon_h} = \varrho_{\varepsilon_h} \tau_{\varepsilon_h}$): as $(\tau_{c_h} G_h)$ converges pointwise P -almost everywhere to $\tau_c F_0$ and (F_{ε_h}) to F_0 , we obtain that $\tau_c F_0 \sim F_0$ and the proposition is proved.

The following is the main result of our work.

3.2. THEOREM. - Let (F_ε) be a stochastic homogenization process modelled on a stochastically periodic random integral functional F . Suppose that there exists $M > 0$ such that the two families of random functions

$$(F(\cdot)(u, A))_{u \in L^2_{loc}(\mathbf{R}^n)}, \quad (F(\cdot)(u, B))_{u \in L^2_{loc}(\mathbf{R}^n)}$$

are independent whenever $A, B \in \mathcal{A}_0$ with $\text{dist}(A, B) \geq M$. Then (F_ε) converges in probability as $\varepsilon \rightarrow 0^+$ to the single functional $F_0 \in \mathcal{F}$ independent of ω (i.e. to the constant random integral functional F_0) given by

$$F_0(u, A) = \begin{cases} \int_A f_0(Du(x)) \, dx & \text{if } u|_A \in W^{1,\alpha}(A) \\ +\infty & \text{otherwise} \end{cases}$$

where, for $p \in \mathbf{R}^n$,

$$(25) \quad f_0(p) = \lim_{\varepsilon \rightarrow 0^+} \int_{\Omega} \min_u \left\{ \frac{1}{|Q_{1/\varepsilon}|} F(\omega)(u, Q_{1/\varepsilon}) : u(x) - p \cdot x \in W_0^{1,\alpha}(Q_{1/\varepsilon}) \right\} dP(\omega),$$

$Q_{1/\varepsilon}$ is the cube $\{x \in \mathbf{R}^n : |x_i| < 1/\varepsilon, i = 1, \dots, n\}$ and $|Q_{1/\varepsilon}| = (2/\varepsilon)^n$ is its Lebesgue measure.

PROOF. - By proposition 2.9 it suffices to prove that (F_ε) converges in law as $\varepsilon \rightarrow 0^+$ to F_0 . Let $\mu_\varepsilon = F_{\varepsilon\#}P$ be the image measure of F_ε on \mathcal{F} and μ_0 be the Dirac measure centered at F_0 . Since \mathcal{F} is a compact metric space, $C^0(\mathcal{F}, \mathbf{R})$ is a separable Banach space, hence the bounded subsets of its dual space are metrizable and weak*-compact (e.g. see [20], th. 3.15-3.16). As $\mu_\varepsilon(\mathcal{F}) = 1$ for every $\varepsilon > 0$, in order to prove the weak* convergence of (μ_ε) toward μ_0 , it will suffice to prove that, if $\varepsilon_n \rightarrow 0^+$ and (μ_{ε_n}) weak* converges to μ , then $\mu = \mu_0$.

STEP 1. - μ is a Dirac measure on \mathcal{F} .

Since $\mu_\varepsilon(\mathcal{F}) = 1$ for every $\varepsilon > 0$, we have $\mu(\mathcal{F}) = 1$.

Let $(\Omega_\infty, \mathcal{G}_\infty, P_\infty)$ be the probability space $(\mathcal{F}, \mathcal{G}_B, \mu)$ and $F_\infty: \Omega_\infty \rightarrow \mathcal{F}$ be the trivial random functional given by the identity map. We have that $(\varrho_{\varepsilon_n} F)$ converges in law to F_∞ because $(\varrho_{\varepsilon_n} F)_{\#}P = F_{\varepsilon_n\#}P = \mu_{\varepsilon_n}$, $F_{\infty\#}P_\infty = \mu$, hence by theorem 2.5 with $\Omega_h = \Omega$ for every $h \in N$

$$\lim_{\varepsilon \rightarrow 0^+} \lim_{h \rightarrow +\infty} \text{cov}(T_\varepsilon \varrho_{\varepsilon_h} F(\cdot)(u, A), T_\varepsilon \varrho_{\varepsilon_h} F(\cdot)(u, B)) = \text{cov}(F_\infty(\cdot)(u, A), F_\infty(\cdot)(u, B))$$

for every $u \in W^{1,\alpha}(\mathbf{R}^n)$ and $A, B \in \mathcal{A}_0$.

Now, choose $A, B \in \mathcal{A}_0$ with $\bar{A} \cap \bar{B} = \emptyset$.

For h large enough,

$$\text{dist}(\varrho_{\varepsilon_h} A, \varrho_{\varepsilon_h} B) = \frac{1}{\varepsilon_h} \text{dist}(A, B) \geq M$$

hence, by hypothesis, the families of random functionals

$$\begin{aligned} (\varrho_{\varepsilon_h} F(\cdot)(u, A))_{u \in L_{loc}^\alpha(\mathbf{R}^n)} &= (\varepsilon_h^n F(\cdot)(v, \varrho_{\varepsilon_h} A))_{v \in L_{loc}^\alpha(\mathbf{R}^n)} \\ (\varrho_{\varepsilon_h} F(\cdot)(u, B))_{u \in L_{loc}^\alpha(\mathbf{R}^n)} &= (\varepsilon_h^n F(\cdot)(v, \varrho_{\varepsilon_h} B))_{v \in L_{loc}^\alpha(\mathbf{R}^n)} \end{aligned}$$

are independent. Proposition 2.7 gives that

$$\text{cov} (T_\varepsilon Q_{\varepsilon_n} F(\cdot)(u, A), T_\varepsilon Q_{\varepsilon_n} F(\cdot)(u, B)) = 0$$

for every $u \in W^{1,\alpha}(\mathbf{R}^n)$, $\varepsilon > 0$ and h large enough, so

$$\text{cov} (F_\infty(\cdot)(u, A), F_\infty(\cdot)(u, B)) = 0, \quad \forall u \in W^{1,\alpha}(\mathbf{R}^n).$$

By theorem 2.8 we conclude that there exists $G_0 \in \mathcal{F}$ such that $F_\infty(\omega) = G_0$ for P_∞ -almost all $\omega \in \Omega_\infty$, so μ is the Dirac measure on \mathcal{F} centered at G_0 .

STEP 2. - The integrand $g_0(x, p)$ of G_0 does not depend on x .

We have proved that the sequence (F_{ε_n}) converges in law to a constant random functional F_∞ , hence proposition 2.9 yields that (F_{ε_n}) converges in probability to F_∞ . From proposition 3.1 we infer that $\tau_c F_\infty \sim F_\infty$ for every $c \in \mathbf{R}^n$. The distribution laws of $\tau_c F_\infty$ and F_∞ are the Dirac measures centered respectively at $\tau_c G_0$ and G_0 , therefore $\tau_c G_0 = G_0$ and, by remark 1.1, $g_0(x + c, p) = g_0(x, p)$ for almost all $x \in \mathbf{R}^n$ and for every $p, c \in \mathbf{R}^n$. In other words, $g_0(x, p)$ does not depend on x .

STEP 3. - f_0 is well-defined by (25).

Fix $p \in \mathbf{R}^n$. For every $A \in \mathcal{A}_0$, denote $X_A = l_p + W_0^{1,\alpha}(A)$ where $l_p(x) = p \cdot x$ and, recalling corollary 1.23, denote for simplicity $\mathcal{M}_A = \mathcal{M}_{A, X_A, 0}$ and $\mathcal{M}_t = \mathcal{M}_{Q_t}$ for $t > 0$ so that

$$\min_u \left\{ \frac{1}{|Q_t|} F(\omega)(u, Q_t) : u(x) - p \cdot x \in W_0^{1,\alpha}(Q_t) \right\} = |Q_t|^{-1} \mathcal{M}_t(F(\omega))$$

for every $\omega \in \Omega$ and $t > 0$. By corollary 2.2, the integral

$$m(t) = \int_\Omega |Q_t|^{-1} \mathcal{M}_t(F(\omega)) dP(\omega)$$

makes sense. We want to prove that there exists $\lim_{t \rightarrow +\infty} m(t)$ and it is finite. Suppose we have proved that

$$(26) \quad m(jk) \leq m(k), \quad \forall j, k \in \mathbf{N}$$

$$(27) \quad t_2^n m(t_2) \leq t_1^n m(t_1) + C(t_2^n - t_1^n), \quad \forall t_1, t_2 \in]0, +\infty[: t_2 \geq t_1$$

for a given real constant $C = C(p, n)$ and let $\lambda = \inf_{k \in \mathbf{N}} m(k)$. Fix $\varepsilon > 0$ and select $k_0 \in \mathbf{N}$ that $m(k_0) \leq \lambda + \varepsilon$. For every $t > 0$, denote by p_t the integer part of t/k_0 and let $q_t = p_t + 1$. As $k_0 p_t \leq t \leq k_0 q_t$ we obtain by (27)

$$m(t) \leq \frac{1}{t^n} [(k_0 p_t)^n m(k_0 p_t) + C(t^n - (k_0 p_t)^n)] \leq m(k_0 p_t) + C \left(1 - \left(\frac{k_0 p_t}{t} \right)^n \right)$$

$$m(t) \geq \frac{1}{t^n} [(k_0 q_t)^n m(k_0 q_t) - C((k_0 q_t)^n - t^n)] \geq m(k_0 q_t) - C \left(\left(\frac{k_0 q_t}{t} \right)^n - 1 \right).$$

By using (26), $k_0 p_i \geq t - k_0$ and $k_0 q_i \leq t + k_0$, we have that

$$\begin{aligned} m(t) &\leq m(k_0) + C \left(1 - \left(\frac{t - k_0}{t} \right)^n \right) \leq \lambda + \varepsilon + C \left(1 - \left(\frac{t - k_0}{t} \right)^n \right) \\ m(t) &\geq m(k_0 q_i) - C \left(\left(\frac{t + k_0}{t} \right)^n - 1 \right) \geq \lambda - C \left(\left(\frac{t + k_0}{t} \right)^n - 1 \right) \end{aligned}$$

and we conclude easily that $\lim_{t \rightarrow +\infty} m(t) = \lambda$.

Let us prove (26) and (27). Fix $j, k \in \mathbf{N}$. The cube Q_{jk} may be subdivided in j^n smaller cubes congruent to Q_k , so we have

$$\left| Q_{jk} - \bigcup_{i=1}^{j^n} \tau_i Q_k \right| = 0$$

where $\tau_i = \tau_{z_i}$ and z_1, \dots, z_{j^n} are suitable points in \mathbf{Z}^n . Fix $\omega \in \Omega$ and denote by u_i a function in $l_p + W_0^{1,\alpha}(\tau_i Q_k)$ such that

$$F(\omega)(u_i, \tau_i Q_k) = \mathcal{M}_{\tau_i Q_k}(F(\omega)).$$

Define piecewise a function u on Q_{jk} by

$$u(x) = u_i(x), \quad \forall x \in \tau_i Q_k.$$

It is very easy to check that $u \in l_p + W_0^{1,\alpha}(Q_{jk})$. Moreover, as

$$F(\omega)(u + c, A) = F(\omega)(u, A), \quad \forall u \in L_{loc}^\alpha(\mathbf{R}^n), A \in \mathcal{A}_0, c \in \mathbf{R},$$

we obtain easily that

$$\mathcal{M}_{\tau_i Q_k}(F(\omega)) = \min \{ \tau_i F(\omega)(v, Q_k) : v - p \cdot z_i - l_p \in W_0^{1,\alpha}(Q_k) \} = \mathcal{M}_k(\tau_i F(\omega))$$

for every $i = 1, 2, \dots, j^n$.

Then, observing that

$$\mathcal{M}_{jk}(F(\omega)) \leq F(\omega)(u, Q_{jk}) = \sum_{i=1}^{j^n} F(\omega)(u_i, \tau_i Q_k) = \sum_{i=1}^{j^n} \mathcal{M}_{\tau_i Q_k}(F(\omega))$$

and recalling that $\mathcal{M}_k(\tau_i F(\cdot)) \sim \mathcal{M}_k(F(\cdot))$ because \mathcal{M}_k is continuous (corollary 1.23) and $\tau_i F \sim F$, we conclude that

$$\begin{aligned} m(jk) &= \int_{\Omega} |Q_{jk}|^{-1} \mathcal{M}_{jk}(F(\omega)) dP(\omega) \leq (2jk)^{-n} \int_{\Omega} \sum_{i=1}^{j^n} \mathcal{M}_{\tau_i Q_k}(F(\omega)) dP(\omega) = \\ &= (2k)^{-n} \int_{\Omega} \mathcal{M}_k(F(\omega)) dP(\omega) = m(k) \end{aligned}$$

and (26) is proved.

Let us pass to (27). Fix $\omega \in \Omega$ and $t_1, t_2 \in]0, +\infty[$ with $t_2 > t_1$. Let u_1 be a function in $l_p + W_0^{1,\alpha}(Q_{t_1})$ such that

$$F(\omega)(u_1, Q_{t_1}) = \mathcal{M}_{t_1}(F(\omega))$$

and define u_2 on Q_{t_2} by extending u_1 on $Q_{t_2} \setminus Q_{t_1}$ with the values of l_p . Then $u_2 \in l_p + W_0^{1,\alpha}(Q_{t_2})$ and by (5)

$$\begin{aligned} \mathcal{M}_{t_2}(F(\omega)) \leq F(\omega)(u_2, Q_{t_2}) &= F(\omega)(u_1, Q_{t_1}) + F(\omega)(l_p, Q_{t_2} \setminus \overline{Q_{t_1}}) \leq \\ &\leq \mathcal{M}_{t_1}(F(\omega)) + c_2 \int_{Q_{t_2} \setminus \overline{Q_{t_1}}} (1 + |Dl_p|^\alpha) dx \end{aligned}$$

hence

$$(2t_2)^n m(t_2) \leq (2t_1)^n m(t_1) + c_2(1 + |p|^\alpha)[(2t_2)^n - (2t_1)^n]$$

and (27) is proved.

STEP 4. - $g_0 = f_0$ hence $\mu = \mu_0$.

Fix $p \in \mathbf{R}^n$ and let $l_p(x) = p \cdot x$. Denote $Q = Q_{\frac{1}{2}}$ so that $|Q| = 1$. For every $u \in l_p + W_0^{1,\alpha}(Q)$, we have that

$$G_0(l_p, Q) = g_0\left(\int_Q Dl_p(x) dx\right) = g_0\left(\int_Q Du(x) dx\right) \leq \int_Q g_0(Du(x)) dx = G_0(u, Q)$$

(the inequality is the Jensen's inequality; see, e.g., [12], 2.4.19), hence

$$g_0(p) = G_0(l_p, Q) = \mathcal{M}_{\frac{1}{2}}(G_0) = \int_{\mathcal{F}} \mathcal{M}_{\frac{1}{2}}(F) d\mu(F).$$

The function $\mathcal{M}_{\frac{1}{2}}$ is continuous on \mathcal{F} (corollary 1.23) and μ is the weak* limit of (μ_{ε_n}) , so

$$g_0(p) = \lim_{h \rightarrow +\infty} \int_{\mathcal{F}} \mathcal{M}_{\frac{1}{2}}(F) d\mu_{\varepsilon_n}(F).$$

As $F_{\varepsilon_n} \sim \varrho_{\varepsilon_n} F$ and μ_{ε_n} is the distribution law of F_{ε_n} , we have that

$$g_0(p) = \lim_{h \rightarrow +\infty} \int_{\Omega} \mathcal{M}_{\frac{1}{2}}(\varrho_{\varepsilon_n} F(\omega)) dP(\omega).$$

Finally

$$\begin{aligned} \mathcal{M}_{\frac{1}{2}}(\varrho_{\varepsilon_n} F(\omega)) &= \min_u \{ \varepsilon_n^\alpha F(\varrho_{\varepsilon_n} u, \varrho_{\varepsilon_n} Q_{\frac{1}{2}}) : u \in l_p + W_0^{1,\alpha}(Q_{\frac{1}{2}}) \} = \\ &= \min_u \{ |Q_{1/2\varepsilon_n}|^{-1} F(v, Q_{1/2\varepsilon_n}) : \varrho_{1/\varepsilon_n} v \in l_p + W_0^{1,\alpha}(Q_{\frac{1}{2}}) \} = \\ &= \min_u \{ |Q_{1/2\varepsilon_n}|^{-1} F(v, Q_{1/2\varepsilon_n}) : v \in \varrho_{\varepsilon_n} l_p + W_0^{1,\alpha}(Q_{1/2\varepsilon_n}) \}. \end{aligned}$$

As $Q_{\varepsilon_n} l_p = l_p$, we conclude that

$$g_0(p) = \lim_{h \rightarrow +\infty} \int_{\Omega} \min_u |Q_{1/2\varepsilon_h}|^{-1} F(v, Q_{1/2\varepsilon_h}) : v \in l_p + W_0^{1,\alpha}(Q_{1/2\varepsilon_h}) \} dP(\omega) = f_0(p)$$

and the theorem is completely proved.

3.3. COROLLARY. - Let $A \in \mathcal{A}_0$, $X \subseteq W^{1,\alpha}(A)$, $\varphi: A \times \mathbf{R} \rightarrow \mathbf{R}$ be satisfying the hypotheses of proposition 1.18. Suppose (F_ε) is a stochastic homogenization process modelled on a stochastically periodic random integral functional F , satisfying the hypothesis of independence of theorem 3.2. Let

$$m_\varepsilon(\omega) = \mathcal{M}_{A,X,\varphi}(F_\varepsilon(\omega)) = \min_{u \in X} \left\{ F_\varepsilon(\omega)(u, A) + \int_A \varphi(x, u(x)) dx \right\}.$$

Then (m_ε) converges in probability as $\varepsilon \rightarrow 0^+$ to m_0 given by

$$m_0 = \mathcal{M}_{A,X,\varphi}(F_0)$$

where F_0 is defined in the statement of theorem 3.2.

PROOF. - The function $\mathcal{M}_{A,X,\varphi}$ is continuous on \mathcal{F} (corollary 1.23) hence uniformly continuous (corollary 1.22). Then for every $\varepsilon > 0$ there exists $\delta(\varepsilon) > 0$ such that

$$P\{\omega \in \Omega : |m_\varepsilon(\omega) - m_0| \geq \varepsilon\} \leq P\{\omega \in \Omega : d(F_\varepsilon(\omega), F_0) \geq \delta(\varepsilon)\}$$

and the thesis follows from theorem 3.2.

3.4. COROLLARY. - Let $A, X, \varphi, F_\varepsilon$ be as in the previous corollary. Suppose that the boundary of A is Lipschitz continuous and that, for every $\varepsilon > 0$ and $\omega \in \Omega$, $F_\varepsilon(\omega)$ belongs to a closed subset \mathcal{G} of \mathcal{F} satisfying the uniqueness of minimum points stated in corollary 1.23. Then $F_0 \in \mathcal{G}$ and, if $u_\varepsilon(\omega)$ denotes the unique minimum point of

$$F_\varepsilon(\omega)(u, A) + \int_A \varphi(x, u(x)) dx$$

for $u \in X$, we have

$$\lim_{\varepsilon \rightarrow 0^+} P\{\omega \in \Omega : \|u_\varepsilon(\omega) - u_0\|_{L^\alpha(A)} > \eta\} = 0, \quad \forall \eta > 0$$

where u_0 is the minimum point in X of

$$F_0(u, A) + \int_A \varphi(x, u(x)) dx.$$

PROOF. – It is the same argument used in the previous corollary. The thesis $F_0 \in \mathcal{G}$ depends on the fact that a sequence which converges in probability contains a subsequence which converges almost everywhere (see e.g. [15], see 6).

3.5. EXAMPLE. – If we choose in the previous corollary \mathcal{G} equal to the set of the quadratic forms (see examples 1.20 and 1.24), we obtain in particular the well-known (see introduction) L^2 -convergence in probability of the solutions of Dirichlet (or Neumann, or other boundary value) problems for stochastic second-order elliptic equations in the presence of homogenization, stationarity (for us, stochastic periodicity) and ergodicity, substituted in this paper by the independence « at large distances » in theorem 3.2.

4. – Examples.

4.1. Homogenization with regular cells occupied by two materials randomly chosen.

For every $\varepsilon > 0$, let $(X_k^\varepsilon)_{k \in \mathbf{Z}^n}$ be a family of independent random variables defined on a probabilistic space (Ω, \mathcal{F}, P) with values $\lambda > 0$ or $\Lambda > 0$ such that

$$P\{\omega \in \Omega: X_k^\varepsilon(\omega) = \lambda\} = r, \quad P\{\omega \in \Omega: X_k^\varepsilon(\omega) = \Lambda\} = 1 - r$$

for every $\varepsilon > 0$, $k \in \mathbf{Z}^n$ and for $r \in]0, 1[$ fixed.

For every $\varepsilon > 0$ and $k \in \mathbf{Z}^n$, let Q_k^ε be the cube in \mathbf{R}^n

$$\{x \in \mathbf{R}^n: \varepsilon k_i \leq x_i < \varepsilon(k_i + 1), i = 1, \dots, n\}$$

and denote by I_k^ε its characteristic function.

Now, let us define

$$a_\varepsilon(\omega, x) = \sum_{k \in \mathbf{Z}^n} X_k^\varepsilon(\omega) I_k^\varepsilon(x) \quad (\omega \in \Omega, x \in \mathbf{R}^n)$$

and

$$F_\varepsilon(\omega)(u, A) = \begin{cases} \int_A a_\varepsilon(\omega, x) |Du(x)|^\alpha dx & \text{if } u|_A \in W^{1,\alpha}(A) \\ + \infty & \text{otherwise} \end{cases}$$

for $u \in L^{\alpha}_{loc}(\mathbf{R}^n)$ and $A \in \mathcal{A}_0$.

If $\alpha = 2$, $F_\varepsilon(\omega)(u, A)$ corresponds to the energy of a dielectric medium in A , subjected to the electric potential u , whose structure is an ε -cubical lattice with cells occupied by two different materials with dielectric constants λ and Λ , chosen independently by a Bernoulli's law.

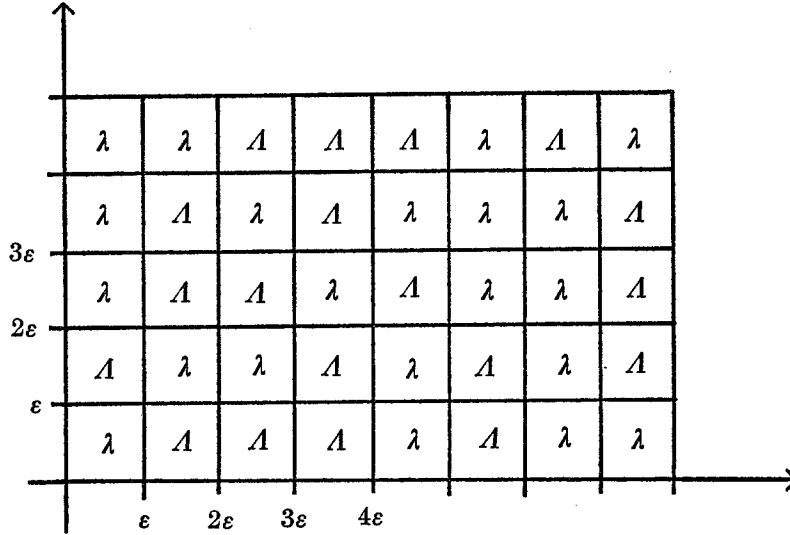

Fig. 3.

It is obvious that, for every $u \in L_{loc}^\alpha(\mathbf{R}^n)$ and $A \in \mathcal{A}_0$

$$\omega \rightarrow F_\varepsilon(\omega)(u, A) = \sum_{k \in \mathbf{Z}^n} X_k^\varepsilon(\omega) \int_A I_k^\varepsilon(x) |Du(x)|^\alpha dx$$

is measurable, so F_ε is a random integral functional (proposition 2.1). Moreover, $F_\varepsilon \sim \varrho_\varepsilon F_1$: indeed

$$I_k^\varepsilon(x) = I_k^1\left(\frac{x}{\varepsilon}\right), \quad \forall \varepsilon > 0, k \in \mathbf{Z}^n, x \in \mathbf{R}^n$$

and the global laws of $(X_k^\varepsilon)_{k \in \mathbf{Z}^n}$ and $(X_k^1)_{k \in \mathbf{Z}^n}$ are equal, so the distribution laws of

$$\begin{aligned} &(\varrho_\varepsilon F_1(\cdot)(u_1, A_1), \dots, \varrho_\varepsilon F_1(\cdot)(u_N, A_N)) \\ &(F_\varepsilon(\cdot)(u_1, A_1), \dots, F_\varepsilon(\cdot)(u_N, A_N)) \end{aligned}$$

are the same for every $u_1, \dots, u_N \in L_{loc}^\alpha(\mathbf{R}^n)$ and $A_1, \dots, A_N \in \mathcal{A}_0$; then $\varrho_\varepsilon F_1 \sim F_\varepsilon$ by proposition 2.3, that is (F_ε) is a stochastic homogenization process modelled on F_1 .

The random functional F_1 is stochastically periodic: indeed, if $z \in \mathbf{Z}^n, A \in \mathcal{A}_0$ and $u \in W^{1,\alpha}(A)$

$$\tau_z F_1(\omega)(u, A) = \sum_{k \in \mathbf{Z}^n} X_k^1(\omega) \int_A I_k^1(x+z) |Du(x)|^\alpha dx = \sum_{k \in \mathbf{Z}^n} X_{k+z}^1(\omega) \int_A I_k^1(x) |Du(x)|^\alpha dx$$

and the global laws of $(X_{k+z}^1)_{k \in \mathbf{Z}^n}$ and $(X_k^1)_{k \in \mathbf{Z}^n}$ are equal so, as above, $\tau_z F_1 \sim F_1$.

Finally, if $A, B \in \mathcal{A}_0$ and $\text{dist}(A, B) > \sqrt{n}$, then there exist two disjoint sets $\{k'_1, \dots, k'_N\}$ and $\{k''_1, \dots, k''_M\}$ in \mathbf{Z}^n such that

$$A \subseteq \bigcup_{i=1}^N Q_{k'_i}^1, \quad B \subseteq \bigcup_{i=1}^M Q_{k''_i}^1$$

and the random vectors $(X_{k'_i}^1)_{i=1, \dots, N}$, $(X_{k''_i}^1)_{i=1, \dots, M}$ are independent.

As

$$F_1(\omega)(u, A) = \sum_{i=1}^N X_{k'_i}^1(\omega) \int_A I_{k'_i}^1(x) |Du(x)|^\alpha dx$$

$$F_1(\omega)(u, B) = \sum_{i=1}^M X_{k''_i}^1(\omega) \int_A I_{k''_i}^1(x) |Du(x)|^\alpha dx$$

for every $u \in W^{1,\alpha}(\mathbf{R}^n)$, it follows that the two families

$$(F_1(\cdot)(u, A))_{u \in L_{\text{loc}}^\alpha(\mathbf{R}^n)}, \quad (F_1(\cdot)(u, B))_{u \in L_{\text{loc}}^\alpha(\mathbf{R}^n)}$$

are independent. Theorem 3.2 applies, so there exists $F_0 \in \mathcal{F}$ such that (F_ε) converges in probability to F_0 as $\varepsilon \rightarrow 0^+$.

In particular, by corollary 3.3, the random variables

$$\omega \rightarrow m_\varepsilon(\omega) = \min \left\{ F_\varepsilon(\omega)(u, A) + \int_A \varphi u \, dx : u - u_0 \in W_0^{1,\alpha}(A) \right\}$$

converge in probability as $\varepsilon \rightarrow 0^+$ to

$$m_0 = \min \left\{ F_0(u, A) + \int_A \varphi u \, dx : u - u_0 \in W_0^{1,\alpha}(A) \right\}$$

whenever $A \in \mathcal{A}_0$, $\varphi \in L^\alpha(A)$ and $u_0 \in W^{1,\alpha}(A)$.

The explicit calculation of F_0 is easy when $n = 1$ (see also [10]). In fact, by (25)

$$(28) \quad f_0(p) = \lim_{j \rightarrow +\infty} \int_0^j \min_u \left\{ \frac{1}{2j} \int_{-j}^j a_1(\omega, t) |u'(t)|^\alpha dt : u(-j) = -jp, u(j) = jp \right\} dP(\omega).$$

By writing the Euler equation of $F_1(\omega)$, we obtain that the function u that attains the minimum in (28) satisfies the equations

$$a_1(\omega, t) |u'(t)|^{\alpha-1} = c \quad \forall t \in]-j, j[\\ u(-j) = -jp, \quad u(j) = jp$$

for a suitable real constant c . By a straightforward calculation, we conclude that

$$\begin{aligned} \min_u \left\{ \frac{1}{2j} \int_{-j}^j a_1(\omega, t) |u'(t)|^\alpha dt : u(-j) = -jp, u(j) = jp \right\} = \\ = \left[\frac{1}{2j} \int_{-j}^j (a_1(\omega, t))^{1/(1-\alpha)} dt \right]^{1-\alpha} p^\alpha = \left[\frac{1}{2j} \sum_{k=-j}^{j-1} (X_k^1(\omega))^{1/(1-\alpha)} \right]^{1-\alpha} p^\alpha \end{aligned}$$

for any $\omega \in \Omega$, so by the strong law of large numbers (see e.g. [15], sec. II)

$$f_0(p) = [r\lambda^{1/(1-\alpha)} + (1-r)A^{1/(1-\alpha)}]^{1-\alpha} p^\alpha$$

and

$$F_0(u, A) = a_0 \int_A |u'(t)|^\alpha dt$$

for every $u \in W^{1,\alpha}(A)$, where a_0 is the α -harmonic r -weighted mean of λ and A . If $\alpha = 2$ and $r = \frac{1}{2}$, a_0 is the harmonic mean of λ and A .

Note that F_0 is equal to the limit in the deterministic case when the cells are alternatively occupied by the two materials. In dimension two with $\alpha = 2$ and $r = \frac{1}{2}$ the corresponding limit is the geometric mean $\sqrt{\lambda A}$ instead of the harmonic mean (see [13]; a proof in the deterministic case has been communicated to us by F. MURAT and L. TARTAR [18]). In three or more dimensions we do not know explicit formulas for F_0 .

4.2. *Homogenization with cells of bounded random size alternatively occupied by two materials.*

As we said in the introduction, the homogenization of chessboard structures with cells of random size can not be treated directly by the results of this paper, even if we think that a careful inspection in the proofs and a not easy estimate of some covariances should permit to include it in our theory.

There is not this difficulty, if we suppose that the random size of the cells is bounded a priori from above. Let us present an example in dimension one.

We want to construct a random partition of \mathbf{R} in intervals not longer than a fixed constant $M > 1$. Suppose we have a family $(X_k)_{k \in \mathbf{Z}}$ of real random variables defined on a probabilistic space (Ω, \mathcal{G}, P) satisfying the following conditions:

- (i) $X_k(\omega) \leq X_{k+1}(\omega)$, $\forall \omega \in \Omega, k \in \mathbf{Z}$;
- ii) $|X_k(\omega) - k| \leq \frac{M-1}{2}$, $\forall \omega \in \Omega, k \in \mathbf{Z}$;
- (iii) the two families $(X_k + 1)_{k \in \mathbf{Z}}$, $(X_{k+1})_{k \in \mathbf{Z}}$ have the same global distribution law;
- (iv) there exists $N > 1$ such that the sub-families $(X_k)_{k \leq -N}$ and $(X_k)_{k \geq N}$ are independent.

To the partition $(X_k(\omega))_{k \in \mathbf{Z}}$ we associate the function

$$a(\omega, t) = \sum_{k=-\infty}^{+\infty} \lambda I_{2k}(\omega)(t) + \Lambda I_{2k-1}(\omega)(t) \quad (\omega \in \Omega, t \in \mathbf{R})$$

where $I_j(\omega)$ is the characteristic function of $[X_j(\omega), X_{j+1}(\omega)]$ for $j \in \mathbf{Z}$ and $\lambda > 0$, $\Lambda > 0$ are given real numbers. In other words, $a(\omega, t)$ takes alternatively the values λ and Λ on the intervals of the partition $(X_k(\omega))_{k \in \mathbf{Z}}$.

Finally, let F_ε be a random integral functional with values in $\mathcal{F}(\lambda, \Lambda, 2)$ such that $F_\varepsilon \sim \rho_\varepsilon F$ where

$$F(\omega)(u, A) = \begin{cases} \int_A a(\omega, t)(u'(t))^2 dt & \text{if } u|_A \in W^{1,2}(A) \\ +\infty & \text{otherwise.} \end{cases}$$

The random functional F is stochastically periodic with period 2: indeed, for every $z \in \mathbf{Z}$, $A \in \mathcal{A}_0$ and $u \in W^{1,2}(A)$

$$\begin{aligned} \tau_{2z} F(\omega)(u, A) &= \int_A a(\omega, t + 2z) u'^2(t) dt = \\ &= \sum_{k=-\infty}^{+\infty} \lambda \int_{X_{2k}(\omega) - 2z}^{X_{2k+1}(\omega) - 2z} I_A(t) u'^2(t) dt + \Lambda \int_{X_{2k-1}(\omega) - 2z}^{X_{2k}(\omega) - 2z} I_A(t) u'^2(t) dt \end{aligned}$$

where I_A is the characteristic function of A . Since the definite integrals are continuous function of the extrema of integration and, by (iii), the global law of $(X_k - 2z)_{k \in \mathbf{Z}}$ is equal to the global law of $(X_{k-2z})_{k \in \mathbf{Z}}$, we infer that

$$\tau_{2z} F(\cdot)(u, A) \sim \sum_{k=-\infty}^{+\infty} \lambda \int_{X_{2k-2z}(\cdot)}^{X_{2k-2z+1}(\cdot)} I_A(t) u'^2(t) dt + \Lambda \int_{X_{2k-2z-1}(\cdot)}^{X_{2k-2z}(\cdot)} I_A(t) u'^2(t) dt = F(\cdot)(u, A)$$

so, as in 4.1, $\tau_{2z} F \sim F$ for every $z \in \mathbf{Z}$.

Now, let $A, B \in \mathcal{A}_0$ with $\text{dist}(A, B) \geq 2N + M + 1$. Define $K_A = \{k \in \mathbf{Z} : \text{dist}(k, A) \leq (M + 1)/2\}$ and analogously K_B . If $[X_k(\omega), X_{k+1}(\omega)] \cap A \neq \emptyset$ for some $k \in \mathbf{Z}$ and $\omega \in \Omega$, then $k \in K_A$; moreover, if $k' \in K_A$ and $k'' \in K_B$, then $|k' - k''| \geq 2N$.

Then, for $u \in W^{1,2}(\mathbf{R})$

$$F(\omega)(u, A) = \int_A \left(\sum_{k \in K_A} \lambda I_{2k}(\omega)(t) + \Lambda I_{2k-1}(\omega)(t) \right) u'^2(t) dt$$

$$F(\omega)(u, B) = \int_B \left(\sum_{k \in K_B} \lambda I_{2k}(\omega)(t) + \Lambda I_{2k-1}(\omega)(t) \right) u'^2(t) dt$$

so, by (iv), $F(\cdot)(u, A)$ and $F(\cdot)(u, B)$ are independent, hence; as in 4.1, theorem 3.2 applies and (F_ε) converges in probability as $\varepsilon \rightarrow 0^+$ to a functional $F_0 \in \mathcal{F}$.

Let us calculate the integrand f_0 of F_0 . We shall prove that

$$(29) \quad \lim_{j \rightarrow +\infty} \frac{1}{2j} \int_{-j}^j \sum_{k \in \mathbb{Z}} I_{2k}(\omega)(t) dt = \frac{1}{2}$$

for P -almost all $\omega \in \Omega$. Since

$$\sum_{k \in \mathbb{Z}} I_{2k+1}(\omega) = 1 - \sum_{k \in \mathbb{Z}} I_{2k}(\omega), \quad \forall \omega \in \Omega$$

we shall obtain easily that

$$f_0(p) = p^2 \lim_{j \rightarrow +\infty} \int_{\Omega} \lambda A \left(\lambda + (A - \lambda) \frac{1}{2j} \int_{-j}^j \sum_{k \in \mathbb{Z}} I_{2k}(\omega)(t) dt \right)^{-1} dP(\omega) = \left(\frac{1/\lambda + 1/A}{2} \right)^{-1} p^2$$

as in the previous case and as in the case of completely random size studied by a direct method in dimension one by G. FACCHINETTI and L. RUSSO [11].

Let us prove (29). Let $L = N + 1$. We have that

$$Y_j(\omega) = \frac{1}{2j} \int_{-j}^j \sum_{k \in \mathbb{Z}} I_{2k}(\omega)(t) dt = \sum_{i=0}^{L-1} \frac{1}{2j} \sum_{m \in \mathbb{Z}} \int_{-j}^j I_{2i+2mL}(\omega)(t) dt.$$

By (ii) we obtain that

$$\int_{-j}^j I_{2i+2mL}(\omega)(t) dt = \int_{-\infty}^{+\infty} I_{2i+2mL}(\omega)(t) dt, \quad \forall \omega \in \Omega$$

if $2i + 2mL - (M - 1)/2 \geq -j$ and $2i + 2mL + 1 + (M - 1)/2 \leq j$, while

$$\int_{-j}^j I_{2i+2mL}(\omega)(t) dt = 0, \quad \forall \omega \in \Omega$$

if $2i + 2mL + 1 + (M - 1)/2 \leq -j$ or $2i + 2mL - (M - 1)/2 \geq j$, so that

$$Y_j(\omega) = \sum_{i=0}^{L-1} \frac{1}{2j} \sum_{m \in \mathbb{S}_1} \int_{-\infty}^{+\infty} I_{2i+2mL}(\omega)(t) dt + \sum_{i=0}^{L-1} \sum_{m \in \mathbb{S}_2} \frac{1}{2j} \int_{-j}^j I_{2i+2mL}(\omega)(t) dt$$

where

$$S_1 = \left\{ m \in \mathbf{Z} : \frac{-2j - 4i + M - 1}{4L} \leq m \leq \frac{2j - 4i - M - 1}{4L} \right\}$$

$$S_2 = \left\{ m \in \mathbf{Z} : \frac{-2j - 4i - M - 1}{4L} < m < \frac{-2j - 4i + M - 1}{4L} \quad \text{or} \right.$$

$$\left. \frac{2j - 4i - M - 1}{4L} < m < \frac{2j - 4i + M - 1}{4L} \right\}.$$

Note that $\# S_2 \leq M/L + 2$, hence

$$\lim_{j \rightarrow +\infty} \sum_{m \in S_2} \frac{1}{2j} \int_{-j}^j I_{2i+2mL}(\omega)(t) dt = 0, \quad \forall \omega \in \Omega, \forall i = 0, \dots, L-1.$$

On the other hand, if $m_1, m_2 \in S_1$ and $m_1 \neq m_2$, the two random variables

$$\omega \rightarrow \int_{-\infty}^{+\infty} I_{2i+2m_rL}(\omega)(t) dt = X_{2i+2m_rL+1}(\omega) - X_{2i+2m_rL}(\omega) \quad (r = 1, 2)$$

are independent by (iv) and have the same distribution law by (iii) so, remarking that $(2j - M)/2L \leq \# S_1 \leq (2j - M)/2L + 1$, the strong law of the large numbers (see e.g. [15], sec. II) and (iii) give that

$$\begin{aligned} \lim_{j \rightarrow +\infty} Y_j(\omega) &= \lim_{j \rightarrow +\infty} \sum_{i=0}^{L-1} \frac{1}{2j} \sum_{m \in S_1} \int_{-\infty}^{+\infty} I_{2i+2mL}(\omega)(t) dt = \\ &= \sum_{i=0}^{L-1} \frac{1}{2L} \int_{\Omega} (X_{2i+1}(\omega) - X_{2i}(\omega)) dP(\omega) = \frac{1}{2L} \sum_{i=0}^{L-1} \int_{\Omega} (X_{2i}(\omega) + 1 - X_{2i}(\omega)) dP(\omega) = \frac{1}{2} \end{aligned}$$

and (29) is proved.

Acknowledgement. - This work has been realized in a National Research Project in Mathematics supported by the Ministero della Pubblica Istruzione (Italy). The authors are members of the [Gruppo Nazionale per l'Analisi Funzionale e le sue Applicazioni (Consiglio Nazionale delle Ricerche)].

REFERENCES

[1] A. BENSOUSSAN - J. L. LIONS - G. C. PAPANICOLAOU, *Asymptotic Methods in Periodic Structures*, North-Holland, Amsterdam, 1978.
 [2] H. BRÉZIS, *Opérateurs Maximaux Monotones et Semigroupes de Contractions dans les Espaces de Hilbert*, Notas de Matemática (50), Mathematics Studies, North-Holland, Amsterdam, 1973.

- [3] R. BURRIDGE *et al.* (ed.), *Microscopic Properties of Disordered Media*, Proceedings ed. by R. BURRIDGE, S. CHILDRESS, G. C. PAPANICOLAOU, New York, 1981. Lecture Notes in Physics, **154**, Springer-Verlag, Berlin-Heidelberg-New York.
- [4] G. BUTTAZZO - G. DAL MASO, *Γ -limits of Integral Functionals*, J. Analyse Math., **37** (1980), pp. 145-185.
- [5] G. DAL MASO - L. MODICA, *A General Theory of Variational Functionals*, in F. STROCCHI *et al.*, Topics in Functional Analysis 1980-81, Scuola Normale Superiore, Pisa, (1981), pp. 149-221.
- [6] E. DE GIORGI, *Generalized Limits in Calculus of Variations*, in F. STROCCHI *et al.*, Topics in Functional Analysis 1980-81, Ann. Scuola Norm. Sup. Pisa, (1981), pp. 117-148.
- [7] E. DE GIORGI - T. FRANZONI, *Su un tipo di convergenza variazionale*, Atti Accad. Naz. Lincei, Rend. Cl. Sci. Mat. Fis. Natur., (8) **58** (1975), pp. 842-850; Rend. Sem. Mat. Brescia, **3** (1979), pp. 63-101.
- [8] E. DE GIORGI - S. SPAGNOLO, *Sulla convergenza degli integrali dell'energia per operatori ellittici del II ordine*, Boll. Un. Mat. Ital., (4) **8** (1973), pp. 391-411.
- [9] I. EKELAND - R. TEMAM, *Convex Analysis and Variational Problems*, Studies in Mathematics and Its Applications, Vol. 1, North-Holland, Amsterdam, 1976.
- [10] G. FACCHINETTI, *Dualità e convergenza stocastica dei minimi* (to appear on Le Matematiche).
- [11] G. FACCHINETTI - L. RUSSO, *Un caso unidimensionale di omogeneizzazione stocastica*, Boll. Un. Mat. Ital., (6) **2-C** (1983), pp. 159-170.
- [12] H. FEDERER, *Geometric Measure Theory*, Springer-Verlag, Berlin-Heidelberg-New York, 1969.
- [13] S. M. KOZLOV, *Averaging of Random Operators*, Math. U.S.S.R. Sbornik, **37** (1980), pp. 167-180.
- [14] K. KURATOWSKI, *Topology*, Academic Press, New York, 1966.
- [15] M. LOÈVE, *Probability Theory*, D. Van Nostrand, Toronto, 1955.
- [16] P. MARCELLINI, *Periodic Solutions and Homogenization of Nonlinear Variational Problems*, Ann. Mat. Pura Appl., (4) **117** (1978), pp. 139-152.
- [17] L. MODICA, *Omogeneizzazione con coefficienti casuali*, Atti Convegno su «Studio di Problemi-Limite dell'Analisi Funzionale», Bressanone, 1981, Pitagora, Bologna, (1982), pp. 155-165.
- [18] F. MURAT - L. TARTAR, Private Communication.
- [19] G. C. PAPANICOLAOU - S. R. S. VARADHAN, *Boundary Value Problems with Rapidly Oscillating Random Coefficients*, Proceed of Colloq. on Random Fields, Rigorous results in statistical mechanics and quantum field theory, ed. by J. FRITZ, J. L. LEBOWITZ, D. SZÁSZ, Colloquia Mathematica Societ. Janos Bolyai, North-Holland, Amsterdam, **10** (1979), pp. 835-873.
- [20] W. RUDIN, *Functional Analysis*, McGraw-Hill, New York, 1973.
- [21] S. SPAGNOLO, *Sulla convergenza delle soluzioni di equazioni paraboliche ed ellittiche*, Ann. Scuola Norm. Sup. Pisa, Cl. Sci., (3) **21** (1967), pp. 657-699.
- [22] F. TREVES, *Basic Linear Partial Differential Equations*, Academic Press, New York, 1975.
- [23] M. M. VAINBERG, *Variational Methods for the Study of Nonlinear Operators*, Holden Day, San Francisco, 1964.
- [24] V. V. YURINSKIĬ, *Averaging an Elliptic Boundary-Value Problem with Random Coefficients*, Siberian Math. Journal, **21** (1980), pp. 470-482.