

The 16th International Conference on RANDOM STRUCTURES AND ALGORITHMS

Pozna , August 5-9, 2013

Information for participants

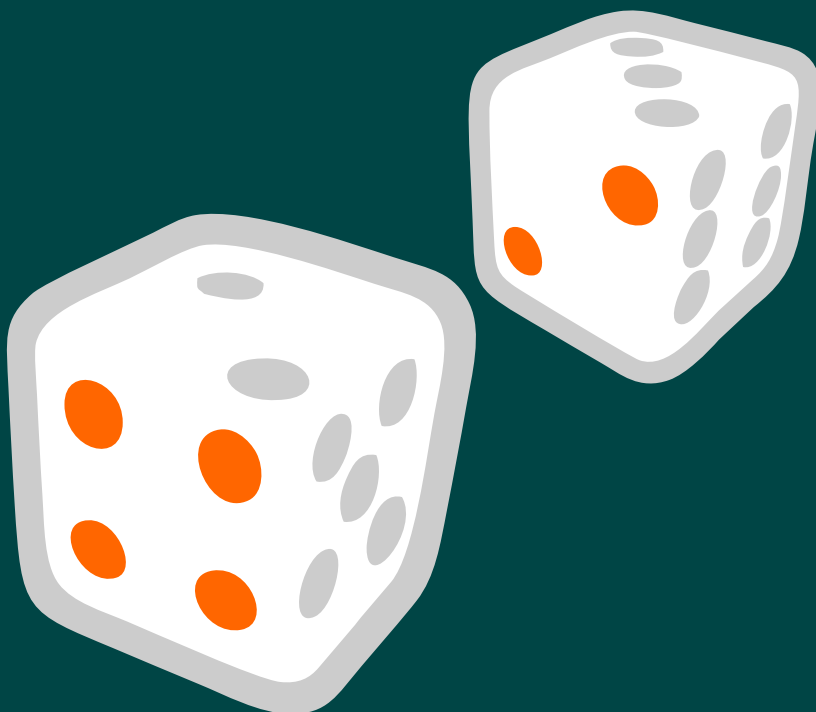



- Travelling to the venue and back
- Map of the Faculty of Mathematics and Computer Science
- Public transport
- Transport and other useful information
- Money exchange and shops
- Customs and other useful information
- Important numbers and wi-fi
- Social events during the conference
- What's going on in Poznań ?
- Restaurants, pubs, cafes
- Maps: Random Run venue, Running trails
- Program

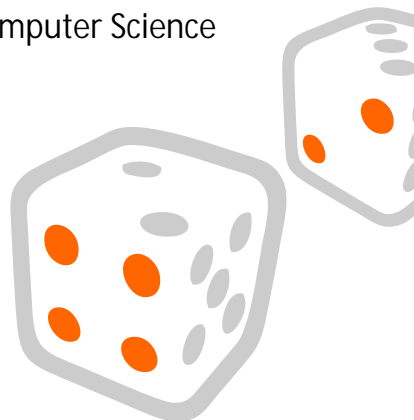

www.rsa2013.amu.edu.pl



Travelling to the venue and back



Every morning at 8:15 am a special bus will leave from Zeylanda Street near conference hotels (see the map) and take the participants directly to the conference venue. The bus can accommodate up to 150 people with both seats and standing place.

To get to the venue using public transportation one can take any tram from the Most Teatralny tram stop which goes in the direction of Os. Sobieskiego, that is, trams no. 8, 12, 14, 15 or 16 (see the map below). There are ticket machines at the Most Teatralny stop, Os. Sobieskiego stop and also one close to the Jowita hotel. You will need a 15-minute ticket for that trip.

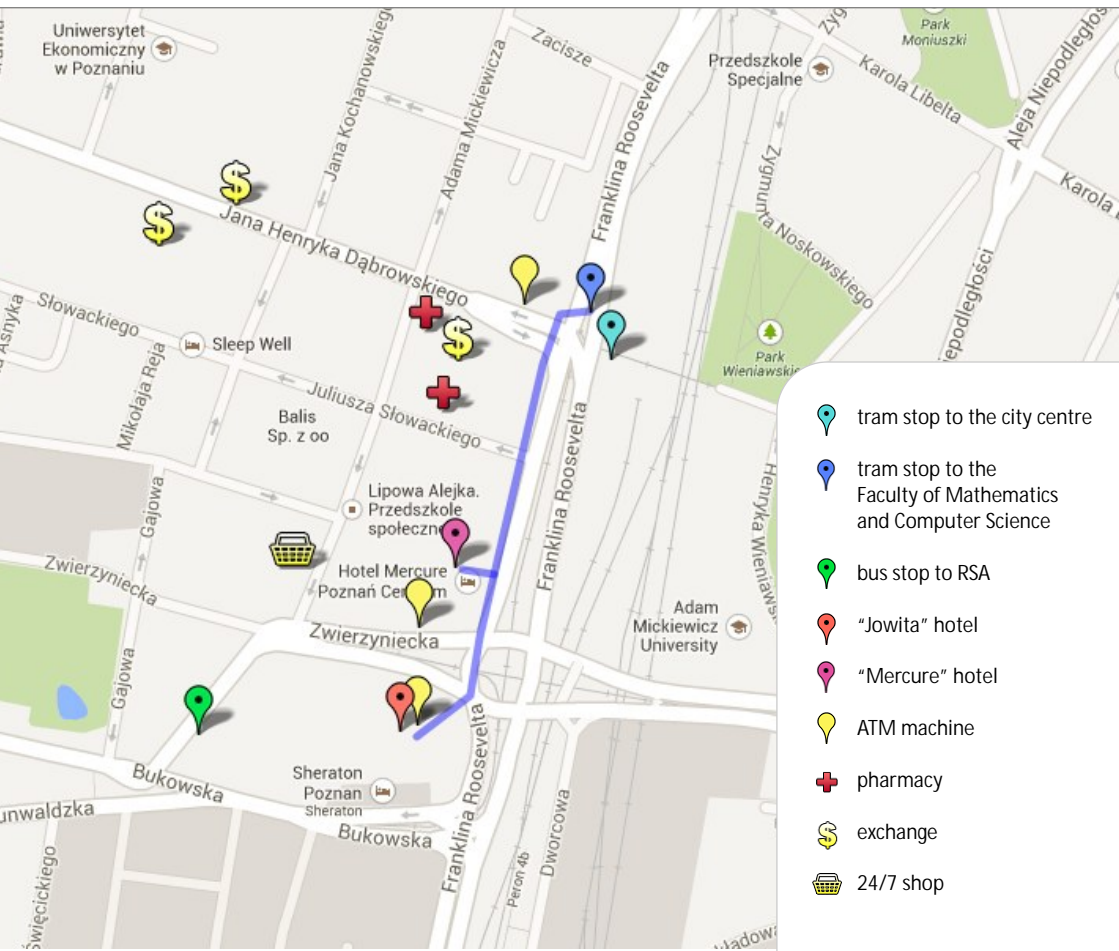

Travelling to the venue and back



Os. Sobieskiego is the last stop on the tram route and once you are there you need to take a 10 minute walk to the Faculty of Mathematics and Computer Science (see the map below). You need to cross the railway and continue along the bicycle road. While walking you will pass near a construction site and afterwards the Faculties of Political Sciences (right hand side) and Biology (left hand side). The Faculty of Mathematics and Computer Science (Coll. Mathematicum) is the second building on the left. It has black / navy blue windows. The main entrance is at the back of the building, by the forest.

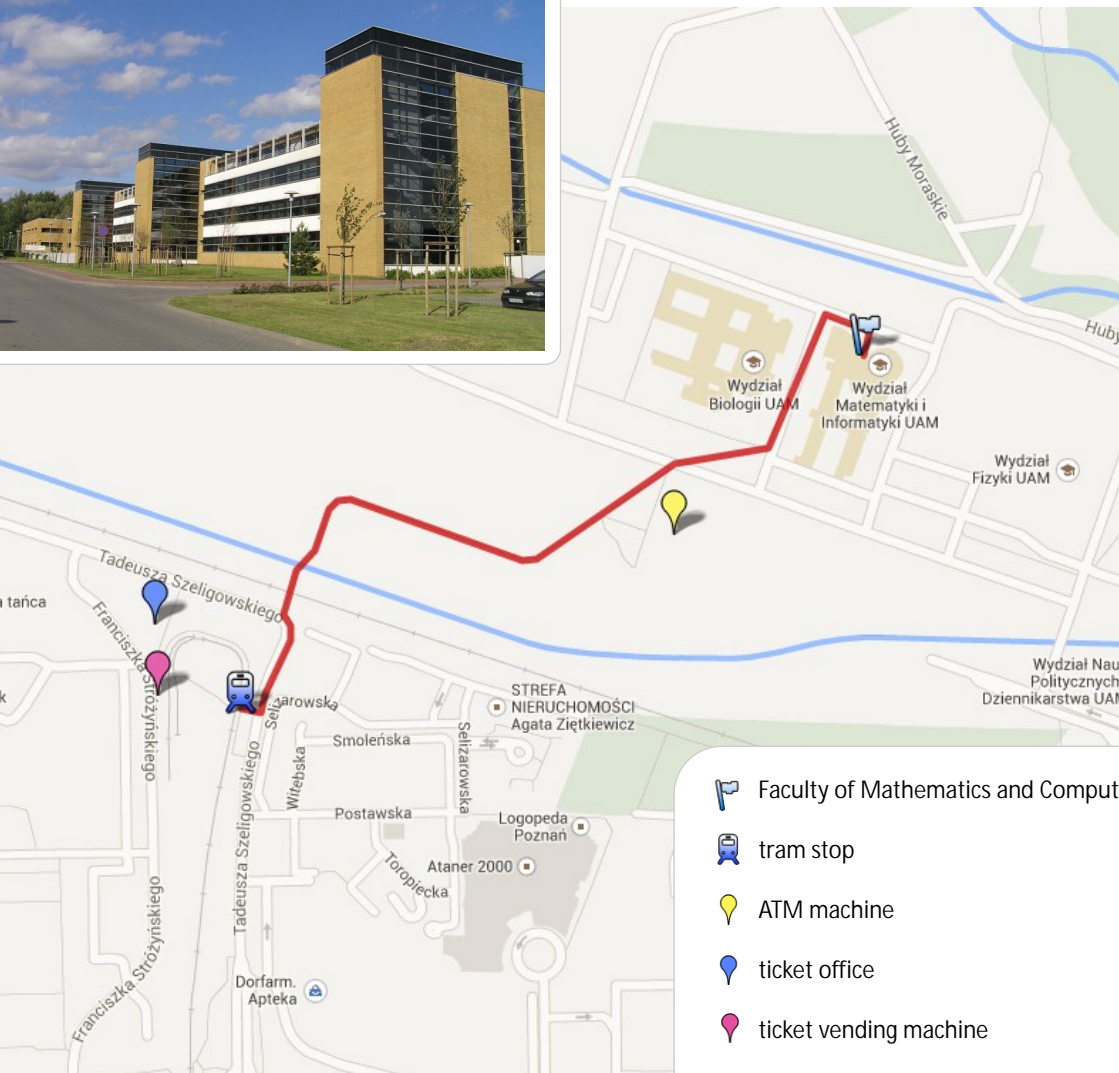



Collegium
 Mathematicum
 Building Plan

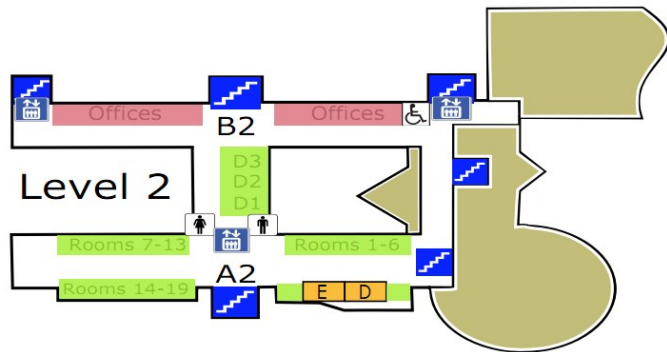
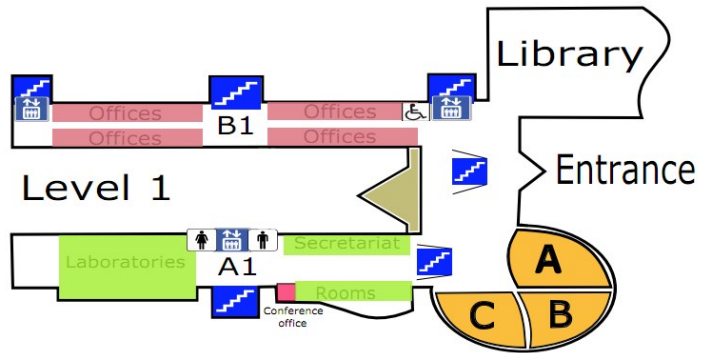
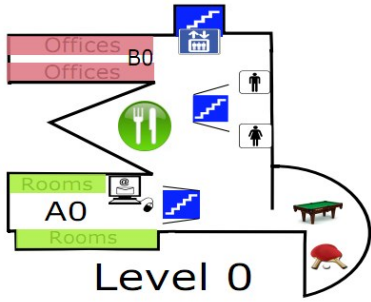

Legend

- Lecture rooms A, B, C, D, E are shown in orange.
- Canteen at the faculty is on level 0 and will be open every day 8 am - 1 pm.
- Computers with the Internet access will be available on level 0.
- Conference office can be found on level 1.



In the city centre, the easiest way to get around is by foot. For longer trips you can use a tram or a bus. To get to the outskirts of town you will find plenty of buses. It is worth buying a one-day ticket, or if you are staying longer, a week ticket. Tickets can be bought in news-stands [kiosk] or in ticket machines located at major stops (for the map, see <http://ztm.poznan.pl/fares-tickets/location-of-ticket-machines>) and some trams and buses. Tickets cannot be bought from the driver.

After boarding the passengers are obliged to validate their tickets in the validating machine immediately after the vehicle starts running (one-day tickets or week tickets should be validated only once when starting the first journey of the day/week). Every ticket is valid for a specified time. After exceeding that time passengers must validate another ticket.

NOTICE: The real time of a ride counts (not schedule time). Due to traffic congestion, from Monday to Friday, between 6 am and 7 pm, 15-minute tickets are valid for 25 minutes and 30-minute tickets for 45 minutes. Similarly, on Saturdays between 8 am and 2 pm.

Daytime trams and buses operate from 5 am to 11 pm. For night timetable and more information see <http://ztm.poznan.pl/>. For planning a trip in Poznań you can use <http://poznan.jakdojade.pl/>.





Type of ticket	Price
Single tickets	
Whole network up to 15 minutes / All bus lines up to 10 stops * - on bus lines is valid up to 10 stops without transfers or up to 15 minutes with transfers to other lines	2,80 PLN
Whole network up to 30 minutes / All bus lines for 1 ride * - on bus lines is valid for the whole line without transfers or up to 30 minutes with transfers to other lines	3,60 PLN
Whole network up to 60 minutes	4,20 PLN
Whole bus service up to 10 bus stops (valid in buses only)	3,00 PLN
Whole bus service for 1 ride (valid in buses only)	3,80 PLN
Short-term tickets	
24-hours, whole network * - validated between 20.00 on Friday and 24:00 on Saturday ticket is valid until 24:00 on Sunday	12,80 PLN
48-hours, whole network	17,20 PLN
72-hours, whole network	21,40 PLN
7-days, whole network	34,20 PLN

Discounts:

100% over 70 years old, after showing an ID, under 5 years old

50% students up to 26 (inclusive) with an ISIC card

If you are going to use discount tickets ask for "ulgowy" ticket (with a symbol U on it).



Taxi

Taxi service in Poznań is very well developed and affordable (very cheap when compared to Western European countries). The initial fare is about 7.00 PLN and about 2.50 PLN per kilometre, (3.75 PLN at night and on holidays), and 35 PLN for one hour waiting time. Typically there is 10-20% discount when you order a taxi over the phone.

- Radio Taxi Club Poznań : +48 61 96 26 or +48 61 830 09 61
- EB. Radio Taxi: +48 96 69 or +48 61 822 22 22
- Halo Taxi Poznań : +48 96 23 or +48 61 821 62 16
- RC Taxi: +48 61 821 92 19
- RADIO TAXI 515: + 48 96 25 or +48 61 8 515 515
- RADIO TAXI 519: +48 96 28 or +48 61 8 519 519

Post Office

For sending postcards or letters you should look for "Poczta". Stamps can be bought from the post office. Post offices are usually open between 8 am - 7 pm.

Pharmacy

If you need a pharmacy, look for "Apteka". Most pharmacies are open weekly 8 am - 6 pm.

Electricity

230 V, 50 Hz. Plugs are the same as in the rest of Continental Europe.





Money exchange / ATM (Bankomat)

In Poland the official currency is zloty (PLN), often abbreviated to zł. You can exchange all major currencies into zloty at many places in Poznań (banks, currency exchange office - kantor). The current exchange rate is app. 3.20 PLN for 1 USD, 4.25 PLN for 1 Euro and 4.90 PLN for 1 Pound. The rate can vary from day to day. To change your foreign currencies into zlotys it is best to go to a KANTOR (bureau de change, currency exchange office). You can also exchange your money in any bank or using ATMs. ATMs and Kantors are very common and easily accessible all over the city.

One ATM machine is conveniently located on the way from the tram stop to the Faculty of Mathematics and Computer Science.

Shops - opening hours

Shops are generally open Mon - Fri 10 am - 6 pm and Sat 10 am - 3 pm. Supermarkets and shopping malls may stay open as late as 10 pm, also on Sundays.

Open Markets

If you are looking for fresh fruit, vegetables, fruits of the forest, mushroom, honey and marinades, you should visit one of Poznań's markets ("rynek"). The most popular of them are Rynek Jezycki, Rynek Łazarski and the ones on Wielkopolski and Bernardyński Squares.





Signs

Toilets are typically marked by one of the signs "Toaleta", "Łazienka" or "WC". Also, it is customary in Poland that ladies' toilets are denoted by a circle or the sign "dla pa ", whereas gents' toilets are denoted by a triangle or the words "dla panów".



Tips

Although tipping at restaurants, clubs, etc. is not obligatory, it is customary to show your appreciation by leaving a tip of around 10-15% of the bill.

When paying for a taxi, you can round up the bill, it prevents hunting for change. Generally, taxi drivers do not expect to be tipped, but if you do the driver will be pleased.

Law: drinking, smoking, walking

Drinking in public places (outside restaurants, pubs or party zones) is illegal (the police can give you a ticket) and also inappropriate.

Smoking at bus/tram stops (both under the roof of the stop and around it) is illegal and you can be fined for it. You cannot smoke in restaurants and bars unless there is a separate smoking area. Smoking on streets, however, is very common.

Jaywalking is illegal and may incur a fine if noticed by a police officer.





Customs

- In Poland, men traditionally let ladies go first.
- Generally you refer to people who are older than you as Mr. or Ms, in case of scientists you say Mr. Prof. or Ms. Prof..
- It is very Polish to shake hands when you introduce yourself, say hello, say goodbye.
- The ability to complain bitterly and at great length is an important skill in Poland. When you start to learn Polish one of the first verbs they teach you is 'narzeka'. Complaining is a valid Polish response to the question "How are you?".
- If you are invited to a Pole's house you may be expected to take off your shoes.
- In Poland, bananas are peeled from the blossom end, not from the stem end.
- Cleaning up after dogs is not yet standard so better watch where you step.



Polish Language

- There is a whole range of Polish words which look pretty similar to their English equivalents, so signs such as POLICJA, RESTAURACJA, HOTEL, TAXI, UNIWERSYTET are hardly going to tax most travellers, but here is a handful of others that may be useful:
- Kawiarnia - Cafe
- Herbaciarnia - Tea House
- Księgarnia - Book Shop
- Nabiał - Dairy products
- Sklep - Shop
- Prasa - Newsagents
- Piwo - Beer



Important telephone numbers:

- Emergency: 112
- Ambulance: 999
- Fire Brigade : 998
- Police: 997
- organizers:
 - Iza Krupi ska: +48 500 140 137
 - Michał Karo ski: +48 601 515 726

Internet Access

- *Conference Venue*

Network name : rsa2013 (password is the same as network name)

- *Mercure*

Wifi is available, ask for details in the Hotel.

- *Jowita*

Eduroam is available on level 0. No wifi in rooms, you need to bring an internet cable to connect to the Internet in the room.





- **Monday** 6 pm - Welcoming Party - **BBQ** outside the Faculty of Mathematics and Computer Science.
- **Tuesday** 9:30 pm - guided night tour of the Kaiser Castle (maximum number of participants is 100).
- **Wednesday - Random Run at "Olimpia"**, at 2 pm a bus will take the participants from the Faculty of Mathematics and Computer Science directly to the stadium. Random Run will start around 5 pm. Changing rooms and showers will be provided at the stadium.
- Before the run, there will be a period of free time. The organizers intend to provide several options to entertain you (play volleyball, frisbee, french skipping etc., there is a possibility to rent a tennis court for playing tennis - price 35-50 PLN for 1h, and 20 PLN for tennis racket, tennis court available until 4 pm), participants are welcome to take a walk in a nearby Sołacki Park, Botanic Garden, Dendrological Garden or around Rusalka lake. There is a possibility to take a swim in Rusalka lake, although the water may not be very clean, so you may want to take your swimming suits with you.
- **Thursday** 7:30 pm - **banquet** at Mercure hotel.



Random Run

RS&A 2013 Poznań



Temporary exhibitions and events 03 - 10.08.2013

- Transatlantyk Festival - The international film and music festival, among others:
- Films screening in Multikino, for details see <http://www.transatlantyk.org/en/>
- Yoko Ono concert - Wednesday, 07.08.2013 at 8 pm in Aula UAM. Tickets around 100-150 PLN.
- Exhibition "Polish Cavalry" - Museum of Armory, Park Cytadela. Tue - Fri 9 am - 5 pm, Sat - Sun 10 am - 4 pm. Tickets: 6.00/3.00 PLN.
- The Castle Chapel – exhibition - Cultural Centre Zamek, Open everyday (except Mondays), 11 am - 7 pm. Entrance is free.
- Exhibition "Elegance – France. The history of 20th century fashion" - Cultural Centre Zamek, Open every day (except Mondays) 11 am - 7 pm. Tickets: 7.00/5.00 PLN.
- Organ Concerts Fara - Fara Church, ul. Gołbia 1. Thursdays 8 pm, Saturdays 12:15 pm. Entrance is free.
- Football Uefa Cup 3rd Round Game - The Municipal Stadium in Poznań, 08.08.2013: Lech Poznań - Žalgiris Vilnius, Ticket prices starting from 40 PLN.
- Free sightseeing walks around Poznań's Old Town - tours start every Saturday at 12:05. Guide waits in front of the Town Hall at Old Market Square. Tour lasts 1,5 hour and presents the most important places in the city center. You can join in with no prior reservation.
- Stare ZOO - (ul. Zwierzyniecka 19) small park with animals just near Jowita and Mercure hotel, opening hours 9 am - 7 pm, free entrance. Entrance to pavilions around 3.00 PLN.

For more information consult the booklet Poznań City Guide enclosed in your conference materials.

Plan of the city can be found at <http://www.poznan.pl/mim/plan/en/>.



Restaurants

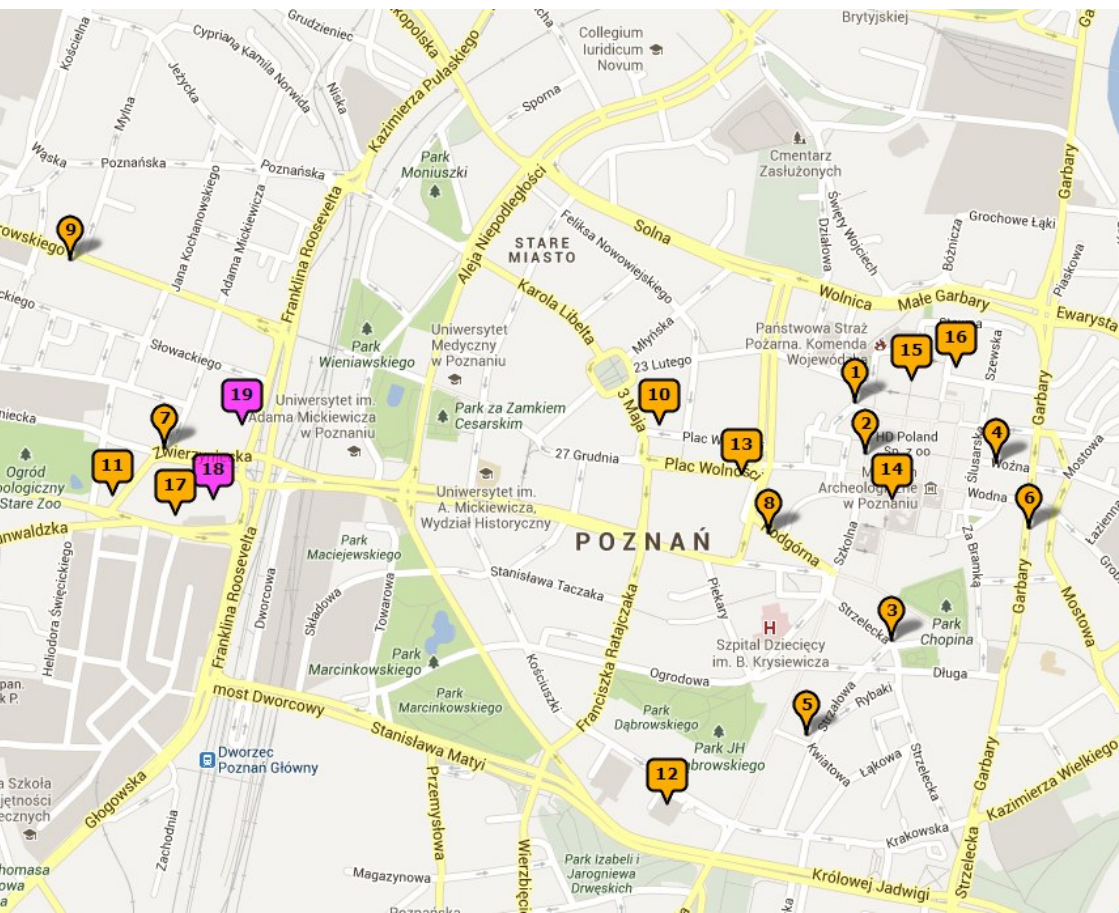

Restaurants



No.	Name	Address	Description	\$
Restaurants				
1	Pika Pika Bar	Zamkowa 5	tapas bar run by a native Spaniard	\$\$
2	Brovaria	Stary Rynek 73-74	beerhouse and restaurant	\$\$\$
3	Pyra Bar	Strzelecka 13	potatoes in 100 ways	\$
4	Pracownia Cafe Restaurant	Wo na 17	nice restaurant with many vegan and vegetarian options	\$\$
5	Manekin	Kwiatowa 3	pancakes at its best	\$\$
6	Dark Restaurant	Garbary 48	eating in full dark?	\$\$\$
7	Concordia Taste	Zwierzyniecka 3	restaurant with nice breakfasts	\$\$
4	Sushi 77	Wo na 10	sushi	\$\$
2	Wiejskie Jadło	Stary Rynek 77	Polish cuisine	\$\$
8	Shivaz Restauracja	Podgórna 6	Indian food	\$\$\$
9	D browskiego 42	D browskiego 42	Mediterranean and Polish cuisine	\$\$\$
10	Mykonos	Plac Wolno ci 14	Greek cuisine	\$\$\$
4	Cymes	Wo na 2	Jewish restaurant	\$\$
11	Bar Metka	Zeylanda 6	traditional food from Wielkopolska	\$\$
12	Mosaica	Plac Andersa 3	stylish restaurant in Andersia hotel	\$\$\$\$
13	de Rome	K. Marcinkowskiego 22	restaurant in hotel Rzymski, Polish and European cuisine	\$\$\$
10	Papavero	3 Maja 46	Italian and Mediterranean cuisine	\$\$\$\$
14	Valpolicella	Wroclawska 7	Italian restaurant	\$\$\$\$
15	Fanaberia	Wroniecka 24	restaurant with a very nice garden	\$\$\$
16	Chimera	Dominika ska 7	restaurant, teahouse, bodega	\$\$
2	Room 55	Stary Rynek 80	a restaurant in the Old Market Square	\$\$\$
17	Cammero	Bukowska 11	steak house	\$\$
18	D.S Jowita			
19	Mercure			

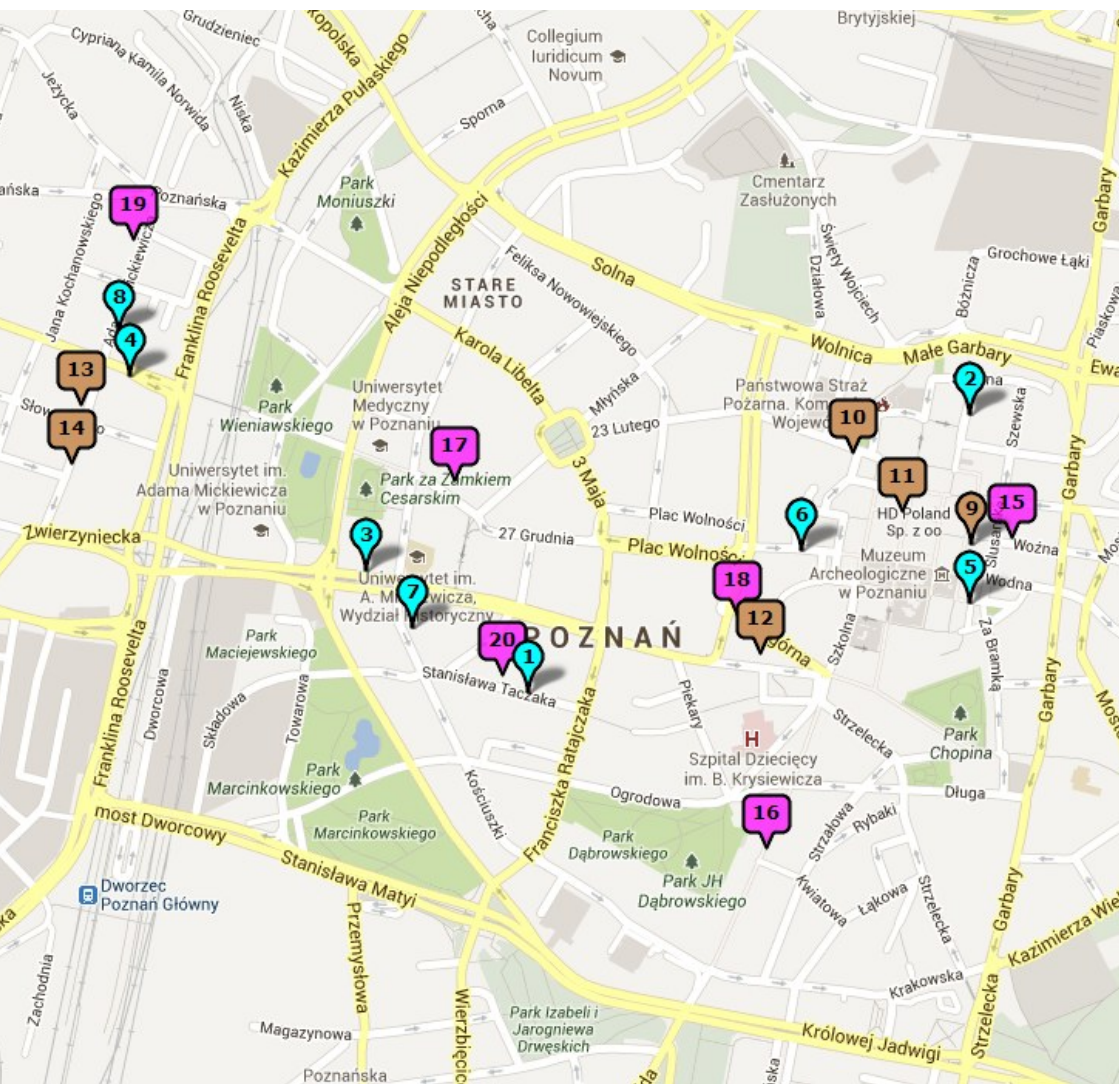

Pubs, bars, cafes











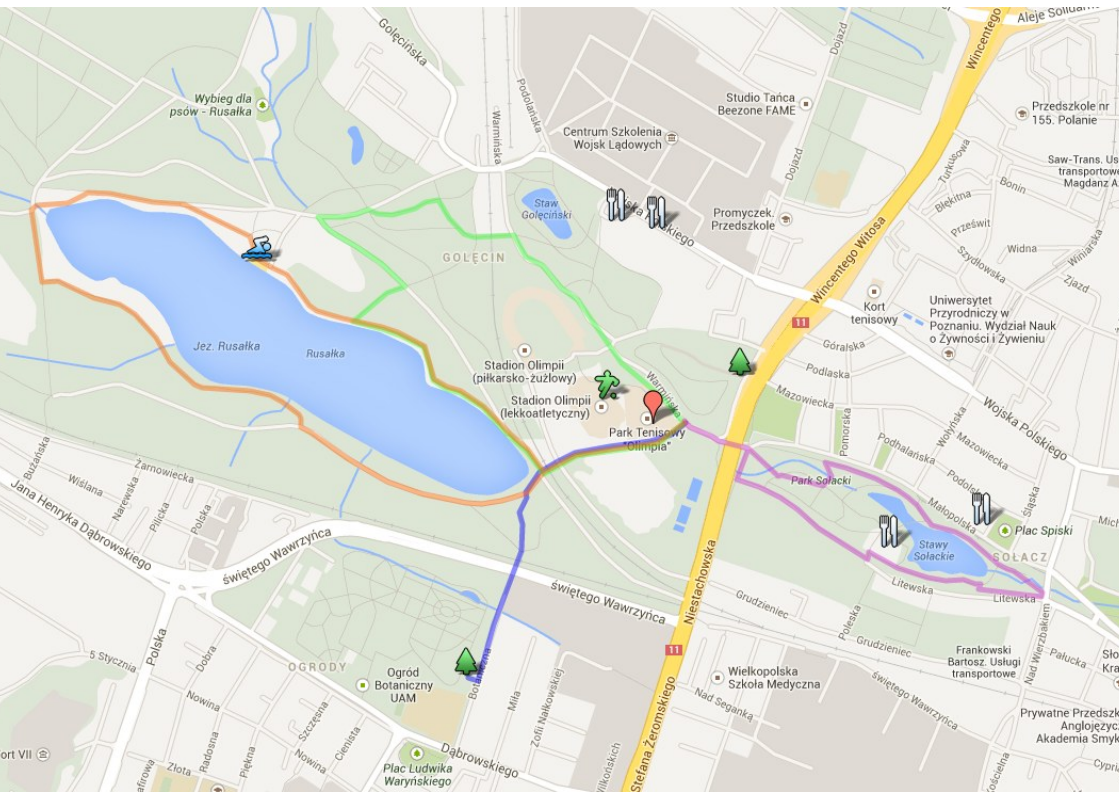

No.	Name	Address	Description	\$
Cafes / Bars				
1	Taczaka 20	Taczaka 20	good quality coffee and nice design	\$\$
1	Ekowiarnia	Taczaka 23	organic cafe	\$\$
2	Piece of Cake	ydowska 29	nice cafe with beautiful garden and delicious veggie burgers	\$\$
3	Bike cafe	near Kaiser Castle	want a good coffee served from a bike?	\$
4	Juice Drinkers	D browskiego 8	delicious fresh juices	\$
5	Republika Ró	Plac Kolegiacki 2	romantic cafe	\$\$
6	Weranda Cafe	Paderewskiego 7	nice cafe/restaurant	\$\$
7	Ptasie Radio	Ko ciuszki 74	cafe with nice hot chocolate	\$\$
8	Brisman Bar Kawowy	Mickiewicza 20	those people know everything about coffee	\$
Pubs				
9	Basilium	Wo na 21	hundred types of beer	\$\$
10	Dragon	Zamkowa 3	cult pub on Pozna map	\$\$
11	Meskalina	Stary Rynek 6	another cult pub in the heart of the Old Market Square	\$
12	Pub Setka	wi ty Marcin 8	beerhouse	\$\$
13	Dylemat	Mickiewicza 27	cafe/pub close to Jowita and Mercure	\$\$
14	Billaboom	Mickiewicza 32	billiards and pub	\$\$
Fast Food / Bistro*				
15	Kwadrat	Wo na 18	vegan bistro	\$\$
16	wi ta krowa	Kwiatowa 1	fast food, burgers	\$
17	Wook	Fredry 12	Asian fast food	\$
17	Viva Pomodori!	Fredry 3	Italian cuisine	\$
18	Przysmak Bar Mleczny	Podgórna 2	PRL-style food	\$
19	Orient Express Bar	Mickiewicza 7	oriental food	\$
20	Friendly Food	Taczaka 17	gluten-free food	\$\$
**	Gallipoli	Królowej Jadwigi 60a	pizzeria	\$
12	CantINETTE	Zeylanda 12	pizzeria	

*Notice: Bistro places are usually open from around 8:00 am to around 6:00 pm.

**Point outside the map

Maps: Random Run venue, Running trails



-  Olimpia stadium
-  Tennis courts
-  Beach (swimming in the lake is possible) and near lake bars
-  Restaurants: "Meridian", "Francuski Ł cznik", "Poezja smaków" and "Pod Sosenk "
-  Gardens: dendrological and botanical
-  Blue path leads to the entrance to Botanical Garden
-  Green path goes near Rusalka lake and motocross stadium
-  Pink path circles around Sołacki park and lake
-  Orange path goes around Rusalka lake and near the beach

Maps: Random Run venue, Running trails

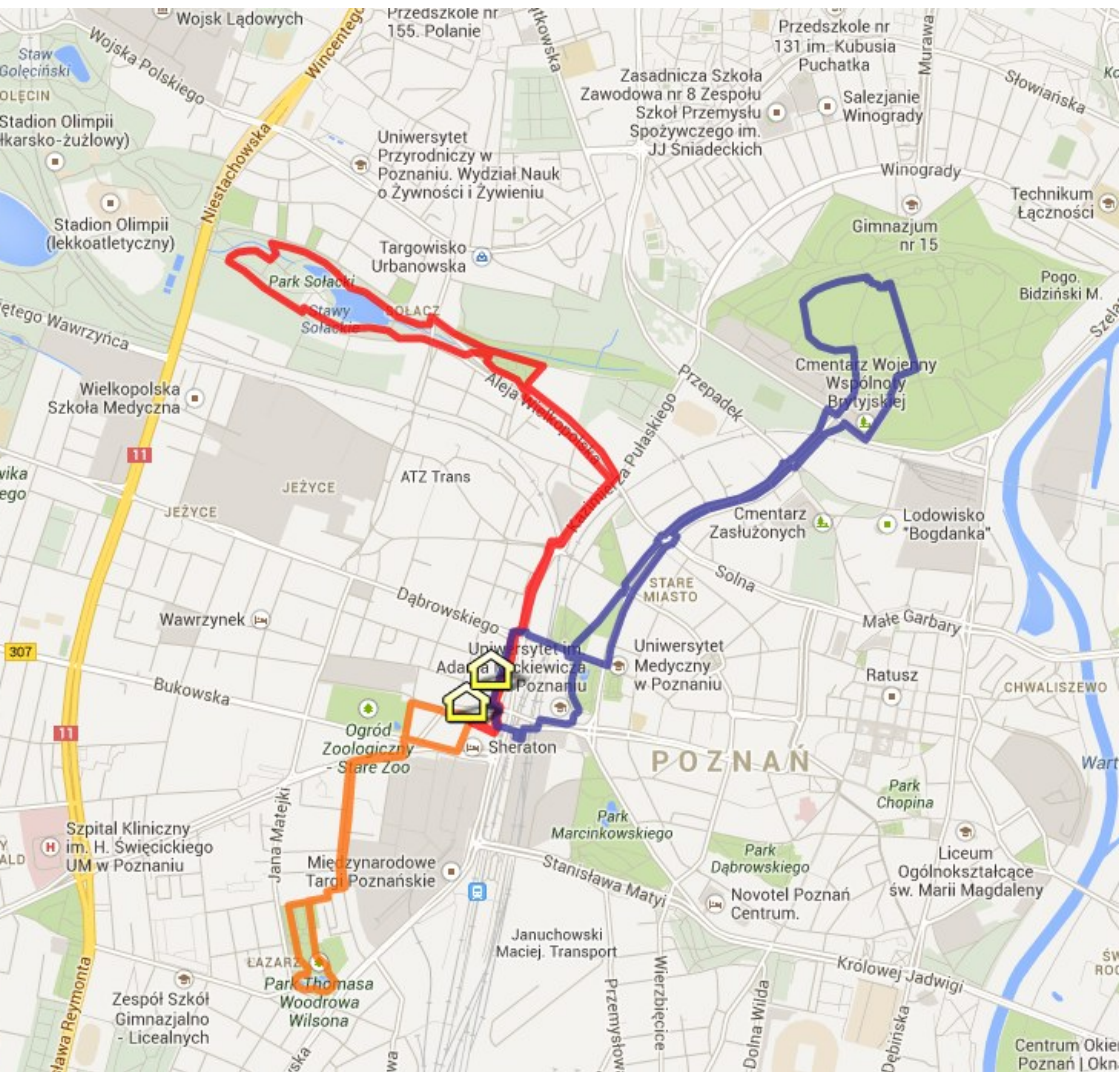

Mercure and Jowita hotels



Around 3.5 km, along quiet niadeckich street to Wilson Park and back



Around 6.35 km, along Roosvelta and Pułaskiego streets, left to Aleje Wielkopolskie, to Sołacki Park and back



Around 6.1 km, along Wieniawskiego street and Aleje Niepodległości to Citadela Park and back



Monday (5.08)

9:00-9:05	Opening ceremony				
9:05-10:00	Béla Bollobás - Bootstrap percolation -- critical probability and speed				
10:00-10:30	coffee break				
10:30-11:10	Alan Frieze - The cover time of random walks on random graphs				
11:15-11:55	Svante Janson - An epidemic on a random graph with given vertex degrees				
12:00-12:40	Geoffrey Grimmett - Counting self-avoiding walks				
12:45	Conference Photo				
13:00-14:00	lunch				
14:30-15:10	Gyula O. H. Katona - Some recent results				
15:15-15:55	Jaroslav Neset II - TBA				
16:00-16:30	coffee break				
16:30-17:10	Vera Sós - Induced subgraphs and Ramsey colorings				
17:15-17:55	Joel Spencer - From Erdos to Algorithms				
18:15	Welcoming Reception				

Tuesday (6.08)

9:00-10:00	Mathias Schacht - Extremal results in random graphs				
10:00-10:30	coffee break				
	A	B	C	D	E
10:30-10:55	Julia Boettcher	Tobias Muller	Oliver Cooley	Małgorzata Sulkowska	Rani Hod
11:00-11:25	Peter Allen	Dieter Mitsche	Christoph Koch	Małgorzata Kuchta	Rajko Nenadov
11:30-11:55	Humberto Naves	Valentas Kurauskas Richard	Stephen Young	John Lapinskas	Asaf Ferber
12:00-12:25	Andrzej Dudek	Montgomery	Tamás Makai	Peter Heinig	Andrew Beveridge
12:30-12:55	Bartosz Zaleski		Michel Bode	Dan Hefetz	Gal Kronenberg
13:00-14:00	lunch				
14:30-15:00	Graham Brightwell - A differential equation method with applications to routing models I				
15:00-15:30	Malwina Luczak - A differential equation method with applications to routing models II				
15:30-16:00	Nick Wormald - A new model for analysis of the random graph d -process				
16:00-16:30	coffee break				
16:30-17:00	József Balogh - Phase transitions in Ramsey-Turan Theory				
17:00-17:30	Colin Cooper - The height of random k -trees and related branching processes				
17:30-18:00	Gregory Sorkin - The Satisfiability Threshold for k -XORSAT				

Wednesday (7.08)

9:05-10:00	Gil Kalai - Influences, thresholds, and tribes				
10:00-10:30	coffee break				
	A	B	C	D	E
10:30-10:55	Richard Mycroft	Paul Russell	Tatyana Turova Schmeling Nikolaos	Cecilia Holmgren	Lale Ozkahya
11:00-11:25	Anand Srivastav	Hi?p Hån	Fountoulakis	Kevin Leckey Liudmila	Kinga D. browska
11:30-11:55	Cyril Banderier	Wenyng Gan	Andrew Uzzell	Ostroumova	Halina Bielak



12:00-12:25	Uwe Roesler	Shagnik Das	Michał Przykucki	John Haslegrave	Sebastian Kieliszek
	Krzysztof				
12:30-12:55	Krzywdzi ski	Jan Volec	Paul Smith	Julia Ehrenmüller	Kamil Powro nik
13:00-14:00	lunch				
	excursion + Random Run				

Thursday (8.08)

9:05-10:00	Michael Krivelevich - Random subgraphs of large minimum degree graphs				
10:00-10:30	coffee break				
	A	B	C	D	E
10:30-10:55	Po-Shen Loh	Pawel Prałat	Roman Glebov	Thomas Vallier	Andreas Noever
			Xavier	Daniel	
11:00-11:25	Paweł Hitztenko	Dominik Vu	Pérez-Giménez	Štefankovi	Mikhail Lavrov
11:30-11:55	Ljuben Mutafchiev	Will Perkins	Alon Naor	Ivona Bezáková	Ross Kang
	Eugenijus		Andrew	Charilaos	
12:00-12:25	Manstavi ius	Maksim Zhukovskii	McDowell	Efthymiou	Andrei Raigorodskii
12:30-12:55	Piotr niady	Svetlana Popova	Jie Ma	Mario Ullrich	
13:00-14:00	lunch				
14:30-15:00	Aravind Srinivasan - Extensions and New Constructive Versions of the Lovasz Local Lemma				
15:00-15:30	Daniel Král - Finitely forcible graphons and permutons				
15:30-16:00	Jacob Fox - A relative Szemerédi theorem				
16:00-16:30	coffee				
16:30-17:00	Benny Sudakov - Cores of random graphs are born Hamiltonian				
17:00-17:30	Stefanie Gerke - Controllability and matchings in random bipartite graphs with a fixed degree distribution				
17:30-18:00	David Conlon - Almost-spanning universality in random graphs				
19:30	Banquet				

Friday (9.08)

9:05-10:00	Oleg Pikhurko - Flag Algebra Method in Extremal Combinatorics				
10:00-10:30	coffee break				
	A	B	C	D	E
10:30-10:55	Wojciech Samotij	Mark Walters	Dmitry Shabanov	Daniel Reichman	Mindaugas Bloznelis
	Angelica Pachon			Urszula	Katarzyna
11:00-11:25	Pinzon	Rob Morris	Andrey Kupavskii	Roma czuk	Rybarczyk
11:30-11:55	Guillem Perarnau	Lutz Warnke	Jakub Przybyło	Monika Polak	Nathan Lemons
12:00-12:25	Abbas Mehrabian	Ali Pourmiri	Pu Gao	Katherine Staden	Victor Falgas-Ravry
12:30-12:55	István Kolossváry	Lajos Vágó	Cristiane Sato	Fiona Skerman	David Penman
13:00-14:00	lunch				
14:00-14:30	Mihyun Kang - Chasing the Giant Component in Random Graph Processes				
14:30-15:30	Noga Alon - The cover number of a matrix and its applications				
	THE END				

