

# MATH 259 – SECOND UNIT TEST

Friday, March 20, 2009.

NAME: \_\_\_\_\_

Alexandra  
Klimova

Oleksii  
Mostovyi

Reshma  
Ramadurai

Stephen  
Russel

William  
Boney

**A**

**C**

**D**

**G**

**H**

**B**

**F**

**E**

## Instructions:

1. Do not separate the pages of the exam. If any pages do become separated, write your name on them and point them out to your instructor when you turn in the exam.
2. Please read the instructions for each individual question carefully. One of the skills being tested on this exam is your ability to interpret questions, so instructors will not answer questions about exam problems during the exam.
3. Show an appropriate amount of work for each exam question so that graders can see your final answer **and** how you obtained it.
4. You may use your calculator on all exam questions except where otherwise indicated. However, if you are asked to find an *exact* value of a quantity that involves an integral then you should not use calculator integration for this.
5. If you use graphs or tables to obtain an answer (especially if you create the graphs or tables on your calculator), be certain to provide an explanation and a sketch of the graph to show how you obtained your answer.
6. Please **TURN OFF** all cell phones and pagers, and **REMOVE** all headphones.

Problem	Total	Score
1	14	
2	16	
3	26	
4	13	
5	15	
6	16	
Total	100	

**1. 14 Points. CLEARLY INDICATE YOUR ANSWERS.**

Suppose that  $f(x, y)$  is a differentiable function of  $x$  and  $y$  and that:

$$g(u, v) = f(e^u + \sin(v), e^u + \cos(v)).$$

Use the values given in the table below to calculate the partial derivatives indicated.

$(x, y)$	$f(x, y)$	$g(x, y)$	$\frac{\partial f}{\partial x}$	$\frac{\partial f}{\partial y}$
$(0, 0)$	3	6	4	8
$(1, 2)$	6	3	2	5

(a) (7 points)  $g_u(0,0)$ .

(b) (7 points)  $g_v(0,0)$ .

**2. 16 Points. SHOW ALL WORK. NO PARTIAL CREDIT WITHOUT WORK.**

In this problem you will be concerned with the function:

$$f(x, y) = x^3 + y^2 - 3x^2 + 10y + 6.$$

- (a) **(8 points)** Find the  $x$  and  $y$  coordinates of all critical points of this function. Record your results in the table provided at the bottom of the next page.

*Continued on the next page.*

**SHOW ALL WORK. NO PARTIAL CREDIT WITHOUT WORK.**

In this problem you will be concerned with the function:

$$f(x, y) = x^3 + y^2 - 3x^2 + 10y + 6.$$

- (b) **(8 points)** Classify each of the critical points of the function. Record your results in the table provided at the bottom of this page.

$x$	$y$	Classification

**3. 26 Points. SHOW YOUR WORK. NO WORK = NO CREDIT.**

Consider a surface  $z = f(x, y)$  where  $f(x, y)$  is a differentiable function. All that you may assume about  $f(x, y)$  is that:

(I)  $f(2, 1) = 3$ .

(II) The curves defined by the vector functions  $\vec{r}_1(t) = \langle 2 + 3t, 1 - t^2, 3 - 4t + t^2 \rangle$ ,  $\vec{r}_2(u) = \langle 1 + u^2, 2u^3 - 1, 2u + 1 \rangle$  and their tangent vectors lie entirely in the tangent plane to  $z = f(x, y)$  based at the point  $(2, 1, 3)$ .

(a) **(6 points)** Find a unit tangent vector to the curve defined by the vector equation:

$$\vec{r}_1(t) = \langle 2 + 3t, 1 - t^2, 3 - 4t + t^2 \rangle$$

at the point on the curve where  $(x, y, z) = (2, 1, 3)$ .

(b) **(6 points)** Find a unit tangent vector to the curve defined by the vector equation:

$$\vec{r}_2(u) = \langle 1 + u^2, 2u^3 - 1, 2u + 1 \rangle$$

at the point on the curve where  $(x, y, z) = (2, 1, 3)$ .

*Continued on the next page.*

**SHOW YOUR WORK. NO WORK = NO CREDIT.**

Consider a surface  $z = f(x, y)$  where  $f(x, y)$  is a differentiable function. All that you may assume about  $f(x, y)$  is that:

(I)  $f(2, 1) = 3$ .

(II) The curves defined by the vector functions  $\vec{r}_1(t) = \langle 2 + 3t, 1 - t^2, 3 - 4t + t^2 \rangle$ ,  $\vec{r}_2(u) = \langle 1 + u^2, 2u^3 - 1, 2u + 1 \rangle$  and their tangent vectors lie entirely in the tangent plane to  $z = f(x, y)$  based at the point  $(2, 1, 3)$ .

(c) **(10 points)** Find an equation for the tangent plane to  $z = f(x, y)$  based at the point  $(x, y, z) = (2, 1, 3)$ .

(d) **(4 points)** Estimate the value of  $f(2.1, 0.9)$ . If you give your answer as a decimal, include at least four (4) decimal places.

**4. 13 Points. CLEARLY INDICATE YOUR ANSWERS.**

In this problem you will always be concerned with the function:

$$f(x, y) = 3xy + y^2.$$

- (a) **(5 points)** Find the directional derivative of  $f(x, y)$  at the point  $(x, y) = (2, 3)$  in the direction given by the vector  $\vec{v} = \langle 3, -1 \rangle$ . If you give your answer as a decimal include at least four (4) decimal places.
- (b) **(4 points)** In what direction is the directional derivative of  $f(x, y)$  at the point  $(x, y) = (2, 3)$  maximized?
- (c) **(4 points)** Find the maximum rate of change of  $f(x, y)$  at the point  $(x, y) = (2, 3)$ .

**5. 15 Points. NO PARTIAL CREDIT WITHOUT WORK.**

A large rectangular wooden box with a bottom but no lid (see diagram below) is to have a volume of  $32 \text{ m}^3$ . Find the dimensions that minimize the amount of wood used. Record your final answers in the space provided at the bottom of the page.

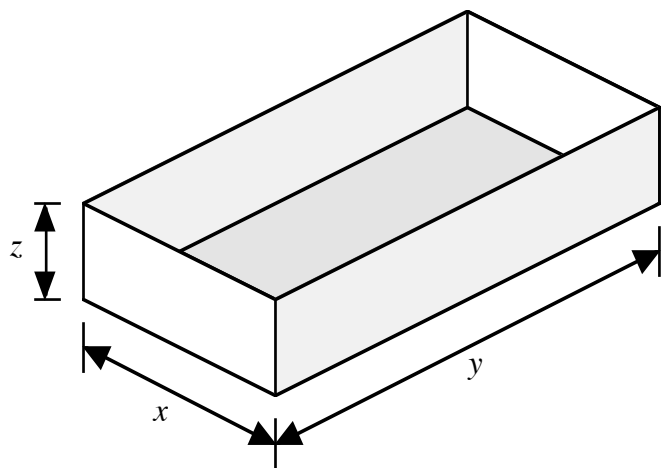
**FINAL ANSWERS:**

$x = \underline{\hspace{2cm}}$

$y = \underline{\hspace{2cm}}$

$z = \underline{\hspace{2cm}}$



6. **16 Points. SHOW YOUR WORK AND EXPLAIN YOUR REASONING.**

(a) **(7 points)** By making the substitution  $y = m \cdot x$ , show that the limit:

$$\lim_{(x,y) \rightarrow (0,0)} \frac{x^2}{x^2 + y^2}$$

does NOT exist.

*Continued on the next page.*

**SHOW YOUR WORK AND EXPLAIN YOUR REASONING.**

**(b) (9 points)** Use the  $\varepsilon$ - $\delta$  definition of a limit to show the following.

$$\lim_{(x,y) \rightarrow (0,0)} \frac{x^3}{x^2 + y^2} = 0.$$