

MATH 120 – FIRST UNIT TEST

Wednesday, February 25, 2009.

NAME: _____

Circle the recitation
section you attend

Tuesday, Thursday
MORNING

Tuesday, Thursday
AFTERNOON

A

B

Instructions:

1. Do not separate the pages of the exam. If any pages do become separated, write your name on them and point them out to your instructor when you turn in the exam.
2. Please read the instructions for each individual question carefully. One of the skills being tested on this exam is your ability to interpret questions, so instructors will not answer questions about exam problems during the exam.
3. Show an appropriate amount of work for each exam question so that graders can see your final answer **and** how you obtained it.
4. You may use your calculator on all exam questions except where otherwise indicated. However, if you are asked to find an *exact* value of a quantity that involves an integral then you should not use calculator integration for this.
5. If you use graphs or tables to obtain an answer (especially if you create the graphs or tables on your calculator), be certain to provide an explanation and a sketch of the graph to show how you obtained your answer.
6. Please **TURN OFF** all cell phones and pagers, and **REMOVE** all headphones.

Problem	Total	Score
1	16	
2	20	
3	18	
4	14	
5	15	
6	17	
Total	100	

1. 16 Points. CLEARLY INDICATE ANSWERS. NO PARTIAL CREDIT FOR (a)-(c).

The table given below shows some of the values of the functions $f(x)$, $g(x)$ and $k(x) = g(f(x))$. Use the information in the table to evaluate the expressions given in Parts (a)-(f) of this problem.

x	$f(x)$	$g(x)$	$k(x) = g(f(x))$
0	4	4	
2	0		4
4	5	2	
5		10	4
6	2		8
8	6	0	6
10		3	0

Parts (a)-(f) are each worth two points.

(a) $k(0) =$ _____

(b) $k(4) =$ _____

(c) $g(2) =$ _____

(d) $g(6) =$ _____

(e) $f(5) =$ _____

(g) $f(10) =$ _____

(h) **(4 points)** A function $p(x)$ is defined by the formula: $p(x) = x^2 + 3$. Use the information contained in the table above to evaluate and simplify the following expression:

$$\frac{p(k(5) + h) - p(k(5))}{h}$$

2. 20 Points. SHOW ALL WORK. NO PARTIAL CREDIT WITHOUT WORK.

In this problem, all that you may assume that $t(x)$ and $s(x)$ are differentiable functions, the domains of both functions include $-4 \leq x \leq 4$ and that they have the graphs shown below.

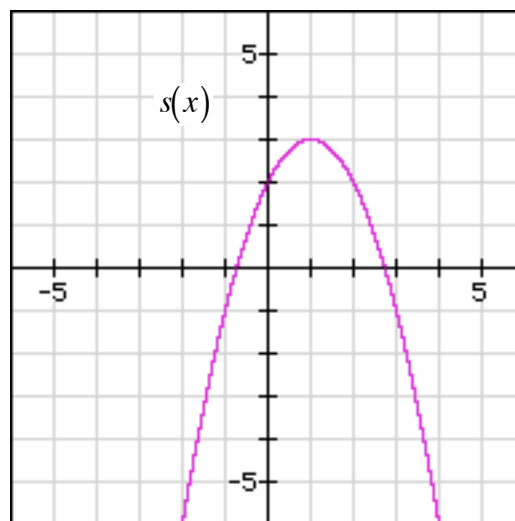
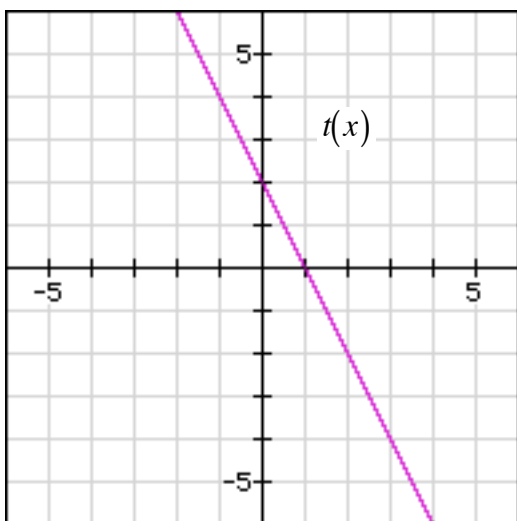

- (a) **(5 points)** Find an accurate estimate for the value of the derivative $k'(1)$ where $k(x) = t(x) \cdot s(x)$.

- (b) **(5 points)** Find an accurate estimate for the value of the derivative $p'(1)$ where $p(x) = \frac{t(x)}{s(x)}$.

Continued on the next page.

In this problem, all that you may assume that $t(x)$ and $s(x)$ are differentiable functions, the domains of both functions include $-4 \leq x \leq 4$ and that they have the graphs shown below.

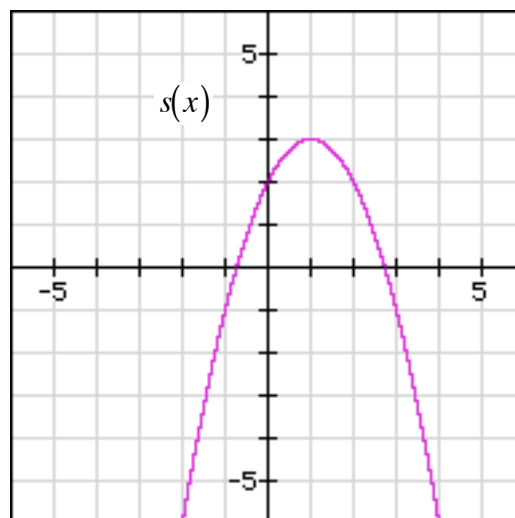
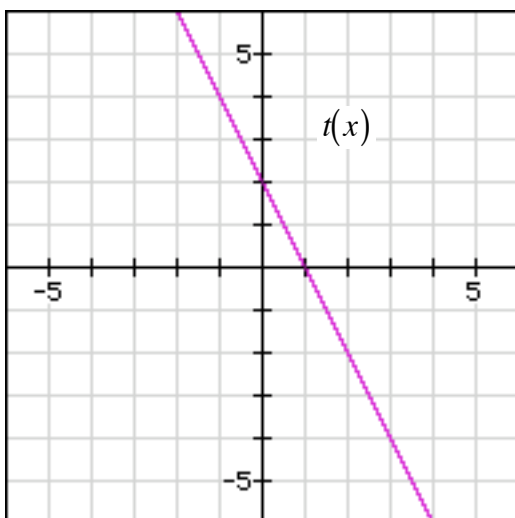

(c) **(5 points)** Find an accurate estimate for the value of the derivative $q'(0)$ where $q(x) = s(t(x))$.

(d) **(5 points)** Find an accurate estimate for the value of the derivative $m'(1)$ where $m(x) = s(s(x))$.

3. 18 Points. SHOW YOUR WORK. NO WORK = NO CREDIT.

In each part of this problem, use algebra to calculate the limit. Clearly indicate the value of the limit that represents your final answer. You should not just plug numbers into your calculator to guess the value of a limit.

If you believe that a limit does not exist, write “DOES NOT EXIST” and show why the limit does not exist (for example, using a graph).

(a) (8 points)
$$\lim_{x \rightarrow \infty} \frac{\sqrt{x} \cdot \sin(x)}{4 + x} .$$

Continued on the next page.

In each part of this problem, use algebra to calculate the limit. Clearly indicate the value of the limit that represents your final answer. You should not just plug numbers into your calculator to guess the value of a limit.

If you believe that a limit does not exist, write “DOES NOT EXIST” and show why the limit does not exist (for example, using a graph).

(b) (10 points)
$$\lim_{u \rightarrow \infty} \frac{4u^4 + 5}{(u^2 - 2) \cdot (2u^2 - 1)}.$$

4. 14 Points. SHOW YOUR WORK. NO WORK = NO CREDIT.

In 1984, engineers working in the Soviet Union set a world record by drilling the deepest hole in the Earth's crust. Let x represent the distance below the surface of the Earth in units of kilometers (km). The engineers found that the temperature, T (in degrees Celsius), of the Earth's crust increased by 2.5°C for each additional 100 meters of depth. There are 1000 meters in one kilometer (km).

- (a) **(4 points)** If the temperature at the depth of 3 kilometers was 30°C , write a formula for T as a function of x . Show your work. No work = no credit.
- (b) **(3 points)** What is the temperature of the Earth's crust at a depth of 15 kilometers?
- (c) **(4 points)** The drilling equipment could only withstand a temperature of 300°C . What is the maximum depth that the hole could have? Show your work.
- (d) **(3 points)** Explain the meaning of the T -intercept of your function from Part (a) in practical terms. (Note that the hole was drilled in Siberia, which is very, very cold.)

5. **15 Points. SHOW YOUR WORK AND EXPLAIN YOUR REASONING.**

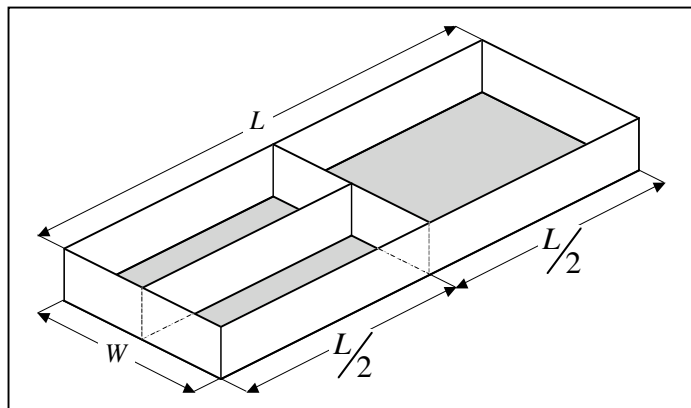

A rancher wants to fence in some grazing land in the pattern shown here. (Note that this diagram is not drawn to scale – the heights of the fences surrounding the grazing land are much higher in this diagram than they would be in reality, for example.)

The rancher plans to create one large field that will take up half the total area. The other half of the land will be divided by a fence into two smaller fields. She has enough funds to buy 45 miles of fencing material.

- (a) **(5 points)** Let $A(W)$ represent the total area of the three fields as a function of width, W , only. Find a formula for $A(W)$.
- (b) **(10 points)** Find the values of L and W that the rancher should use to maximize the area of land covered by the three fields. Do not use your calculator except for arithmetic. Show your all of your work and all of the steps in your calculation. Give appropriate units with your answer. No work, no credit.

6. 17 Points. SHOW ALL WORK. NO WORK = NO CREDIT.

In each case, use the **definition of the derivative** to calculate a formula for $f'(x)$.

You should not use any “short cut” rules that you may know to calculate the formula for $f'(x)$ here. Clearly indicate your final answer.

(a) (7 points) $f(x) = x^2 + \frac{1}{x}$

Continued on the next page.

In each case, use the **definition of the derivative** to calculate a formula for $f'(x)$.

You should not use any “short cut” rules that you may know to calculate the formula for $f'(x)$ here. Clearly indicate your final answer.

(b) (10 points) $f(x) = \frac{1}{\sqrt{x+1}}$